



Real-Time Implementation of Nonlinear Predictive Control

**Michael A. Henson
Department of Chemical Engineering
University of Massachusetts
Amherst, MA**

**WebCAST
October 2, 2008**



Outline

- Limitations of linear model predictive control
- Introduction to nonlinear model predictive control
- Real-time implementation issues
- Nonlinear control of an air separation column
- Final comments

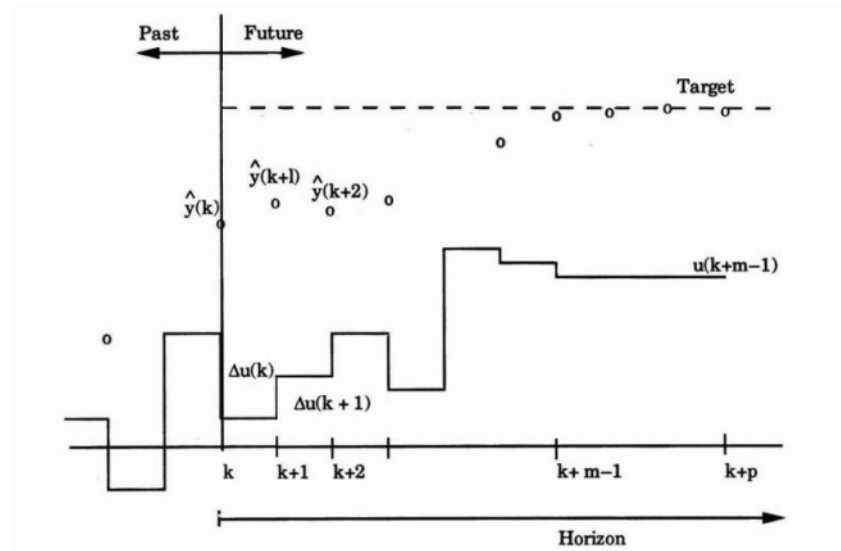

Figure 27.3. The elements of DMC: The "reference trajectory" is the set-point line.

1. Limitations of Linear Model Predictive Control



Linear Model Predictive Control (LMPC)

- Background
 - Constrained multivariable control technology
 - Requires availability of linear dynamic model
 - Chemical process industry standard
- Real-time implementation
 - Repeated on-line solution of optimization problem
 - Receding horizon formulation
 - Computationally efficient & robust quadratic program
- Commercial technology
 - DMCplus (Aspen Technology)
 - RMPCT (Honeywell)
 - Many others

Dynamic Matrix Control (DMC)

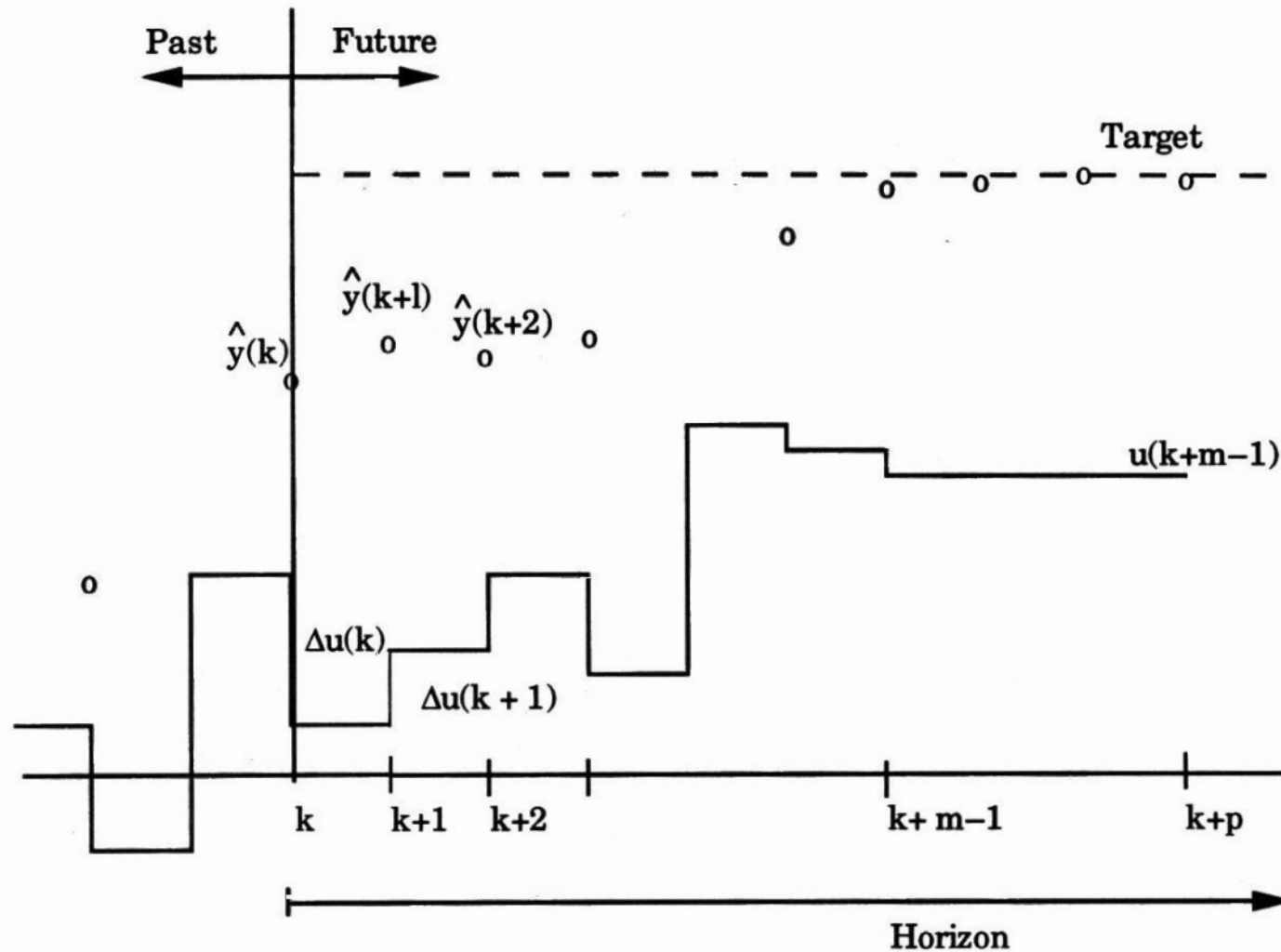

Figure 27.3. The elements of DMC: The “reference trajectory” is the set-point line.



Standard LMPC Formulation

$$\mathbf{Min}_{\Delta U_{f,k}} \Phi = [Y_{k+1} - Y^{\text{sp}}]^T W_e [Y_{k+1} - Y^{\text{sp}}] + \Delta U_{f,k}^T W_{\Delta U} \Delta U_{f,k} \\ + [U_{f,k} - U^{\text{sp}}]^T W_e [U_{f,k} - U^{\text{sp}}]$$

$$\mathbf{S.t} \quad Y_{k+1} = S_f \Delta U_{f,k} + [S_p \Delta U_{p,k} + S_N u_{k-N+1} + d_k]$$

$$U_{f,k} = u_{k-1} + D \Delta U_{f,k}$$

$$U_{\min} \leq U_{f,k} \leq U_{\max}$$

$$\Delta U_{\min} \leq \Delta U_{f,k} \leq \Delta U_{\max}$$

$$Y_{\min} \leq Y_{k+1} \leq Y_{\max}$$

- Controlled variables (Y)
 - Penalize deviations from target values (Y^{sp})
 - Hard lower & upper bound constraints

- Manipulated variables (U)
 - Manipulated to minimize objective function
 - Penalize deviations for target values (U^{sp})
 - Hard constraints on absolute values & rate-of-changes
- Equality constraints
 - Linear step response model identified from plant tests
- Tuning parameters
 - Sampling time
 - Prediction horizon
 - Control horizon
 - Weighting matrices



Triple Column Air Separation Plant

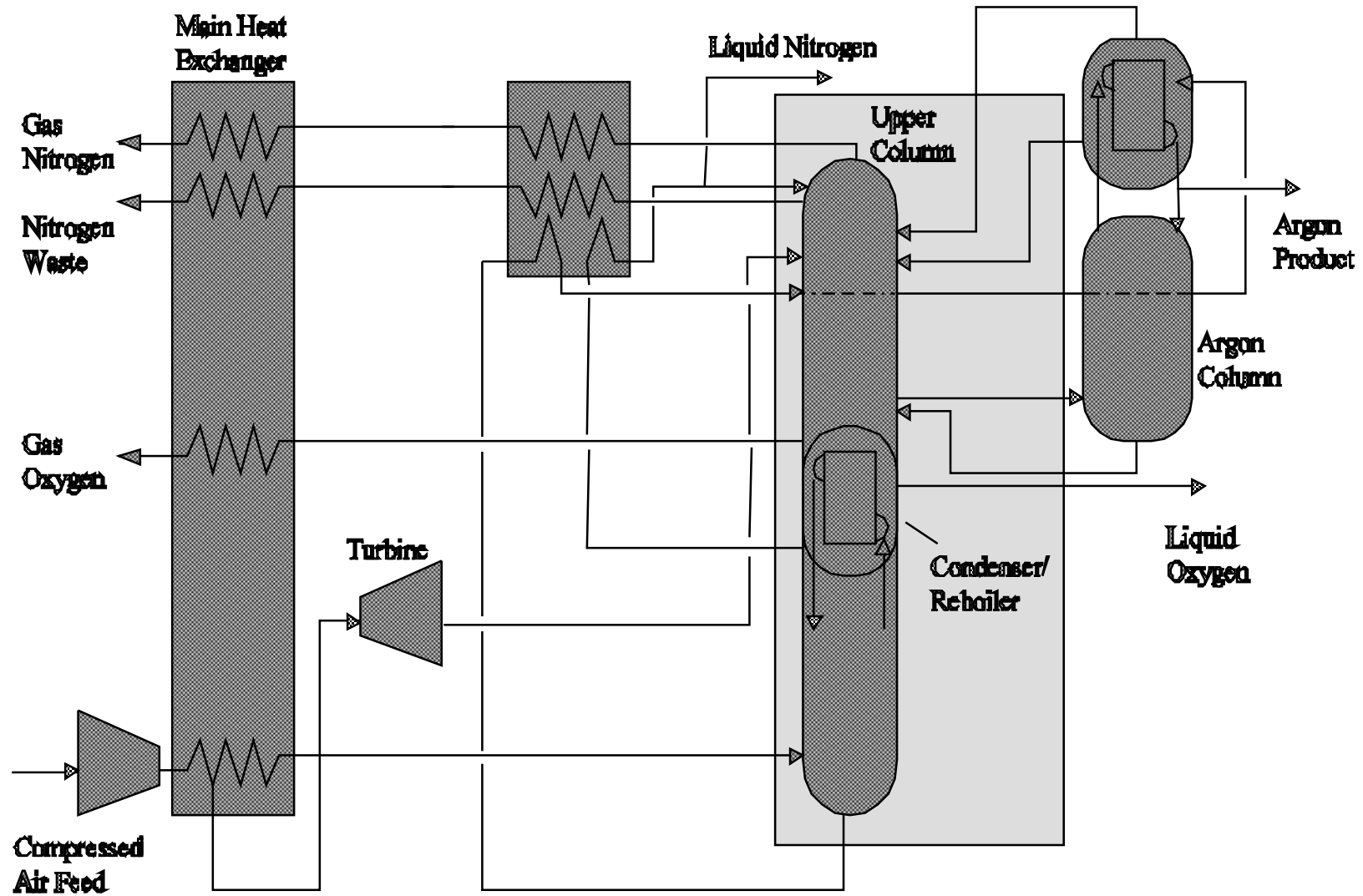



Air Separation Plant Control

- Current practice
 - Empirical linear models & linear model predictive control
 - Adequate for small, well defined operating regimes
- Production rate changes
 - Motivated by electricity industry deregulation
 - Exaggerated nonlinearities
- Plant startup & shutdown
 - Operation over large operating regimes
 - Strong nonlinearities
- Future needs
 - More dynamic operating philosophy
 - Nonlinear behavior more pronounced

Upper Column

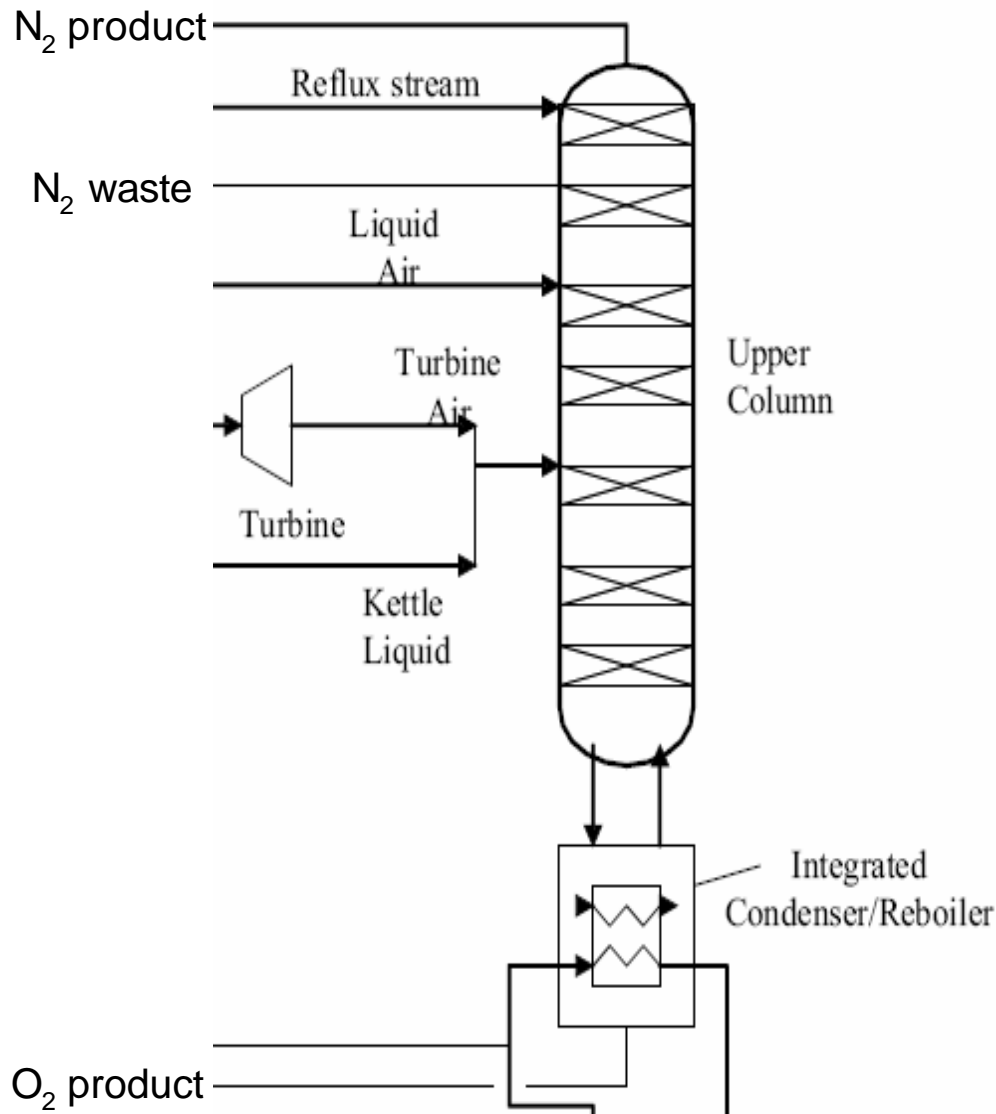

- Packed column modeled with equilibrium stages
- Multiple liquid distributors
- Feeds
 - Reflux from lower column
 - Liquid air
 - Turbine air
- Withdrawals
 - N₂ product
 - N₂ waste
 - O₂ product



Aspen Simulation Model

- Column model RadFrac
 - Dynamic component balances
 - Steady-state energy balances
- Non-ideal vapor-liquid equilibrium
 - NRTL for liquid phase
 - Peng-Robinson for vapor phase
 - Thermodynamic property data provided by Praxair
- PID controllers
 - Reboiler level & overhead pressure
- Coupling to lower column
 - Lower column effect on upper column described by empirical linear models identified from an Aspen model



LMPC Formulation for Upper Column

- Controller variables (2)
 - Log transformed N_2 waste composition
 - Log transformed O_2 product purity
- Manipulated variables (5)
 - Feed flowrates of total air, liquid air & turbine air
 - Liquid N_2 addition rate to top of column
 - Gaseous O_2 production rate
- Constraints
 - Linear step response model identified from step tests on Aspen model
 - Manipulated variable bounds
 - Composition bounds
- Tuning
 - Sampling time = 1 min
 - Prediction horizon = 4 hr
 - Control horizon = 30 min
 - Weighting matrices chosen by trial-and-error



15% Production Rate Changes

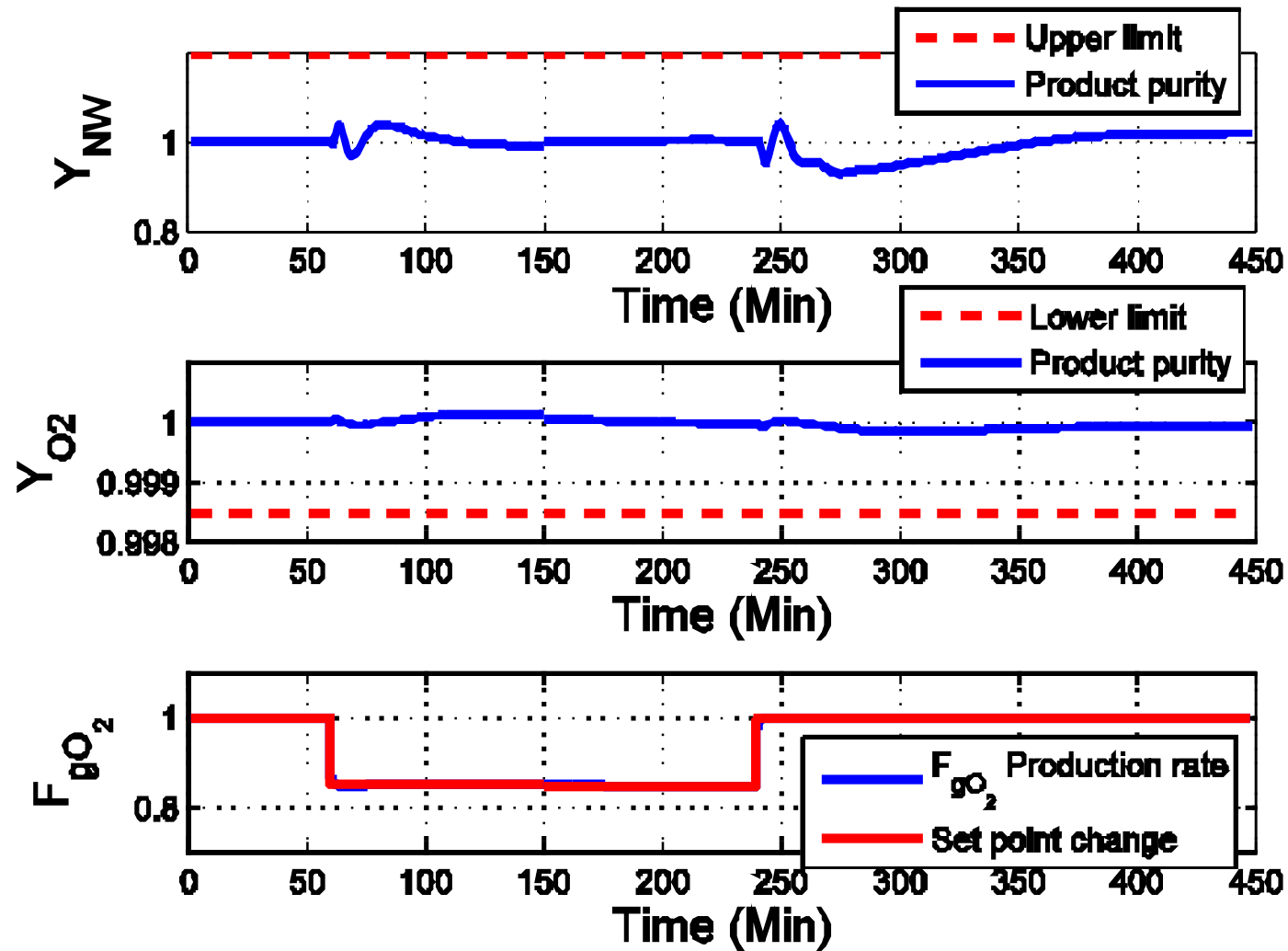



15% Production Rate Changes

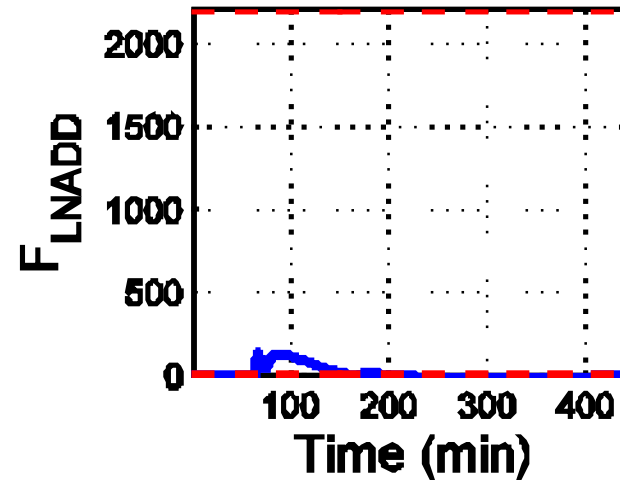
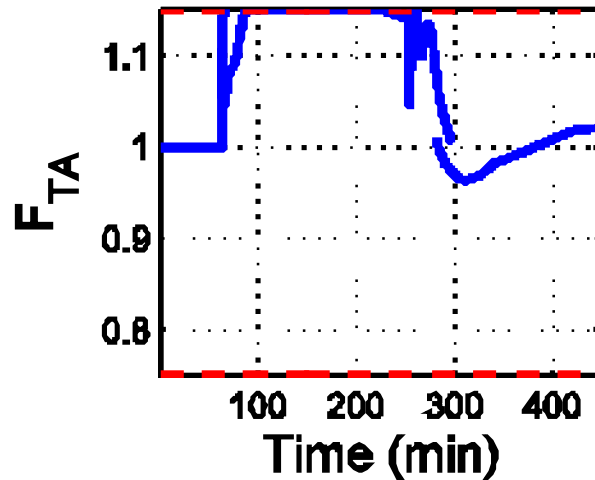
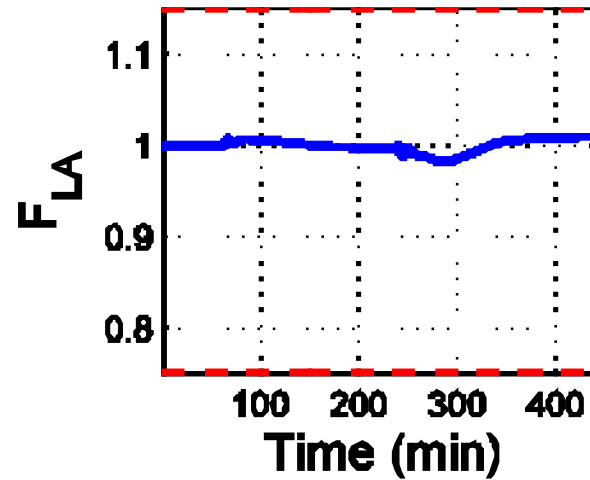
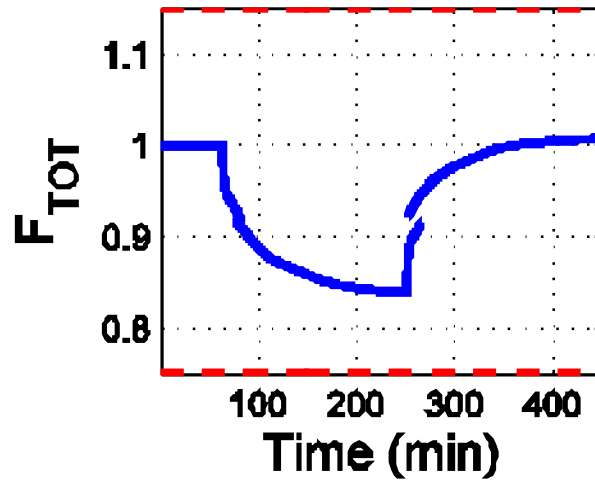



30% Production Rate Changes

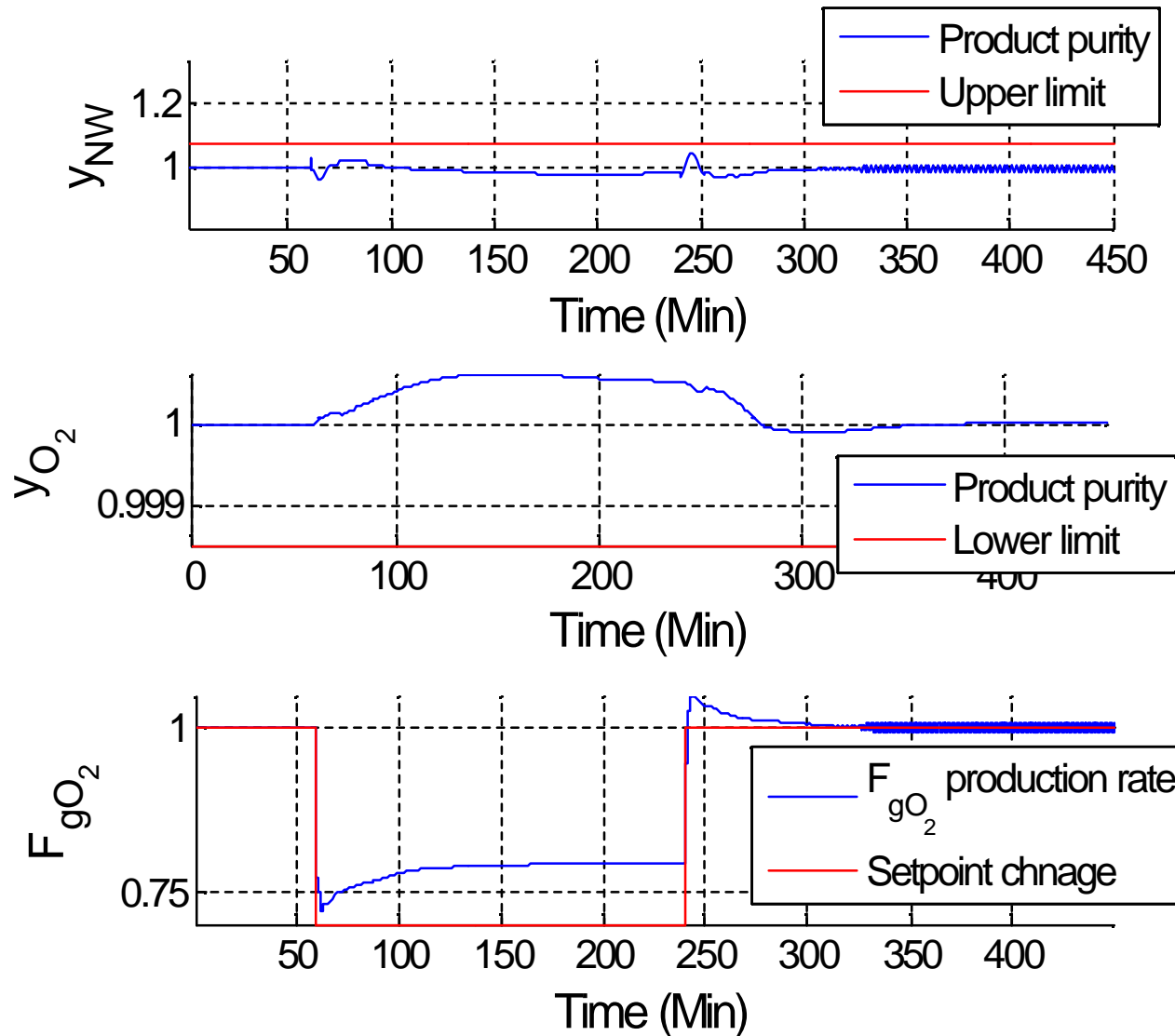



30% Production Rate Changes

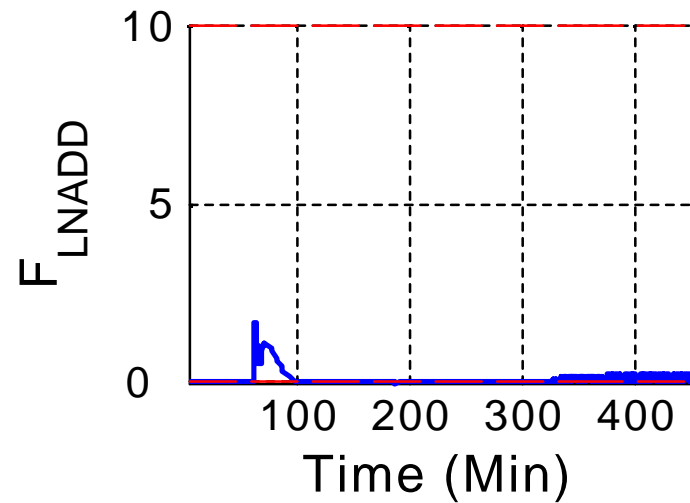
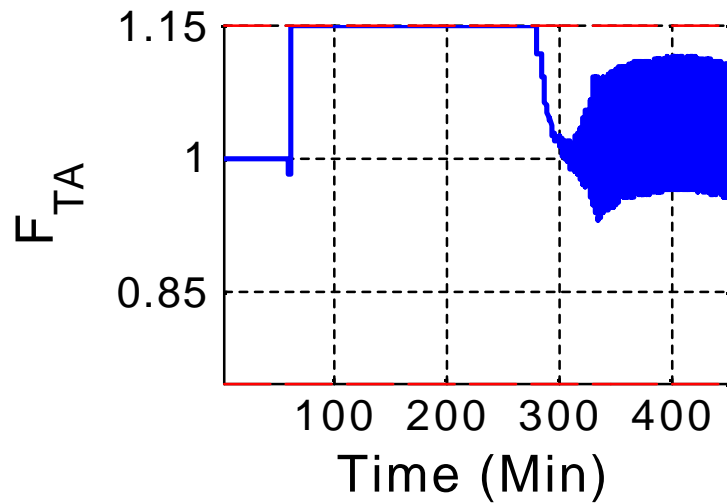
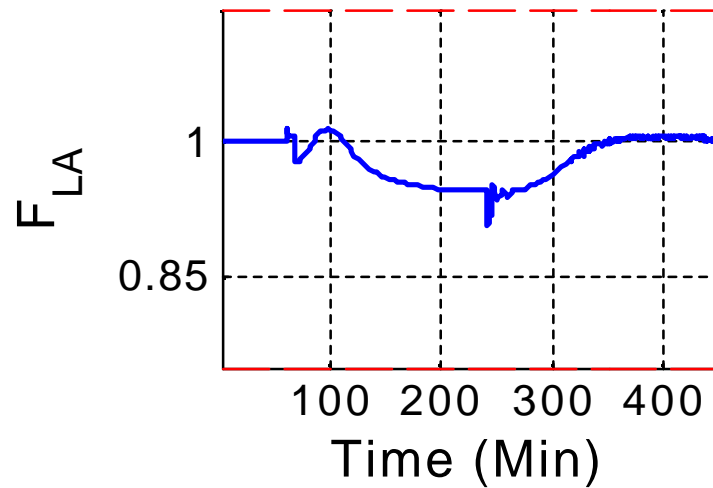
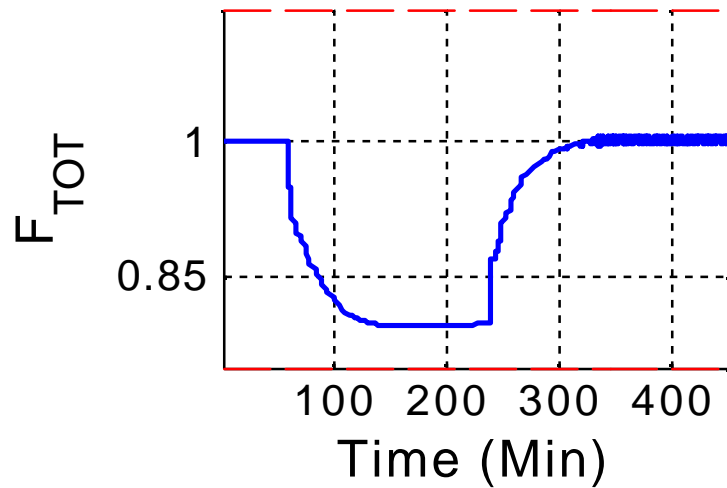



Summary – Part 1

- Linear model predictive control (LMPC) is the industry standard for controlling constrained multivariable processes
- LMPC performance depends strongly on the accuracy of the linear dynamic model
- LMPC can perform very poorly for highly nonlinear processes or moderately nonlinear processes that operate over wide regions
- An extension of LMPC based on nonlinear controller design models is needed for such processes

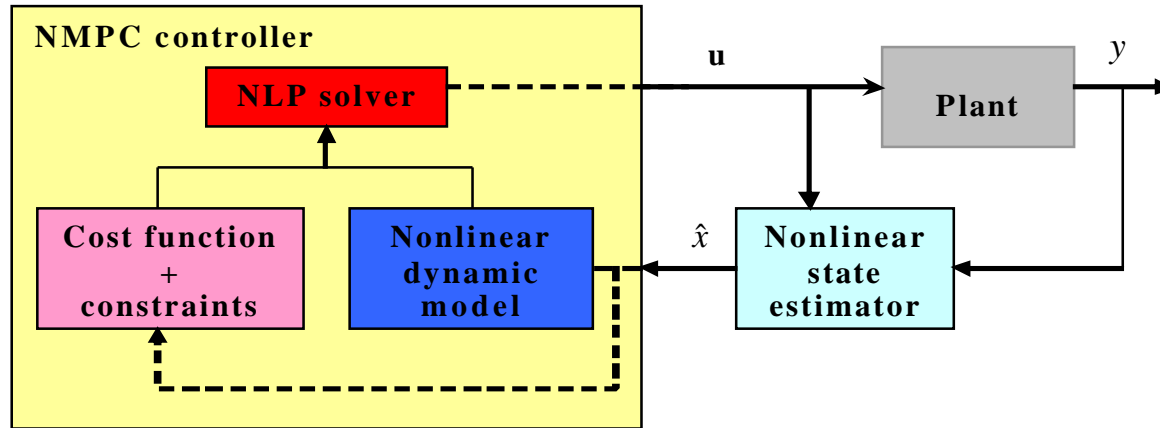

2. Introduction to Nonlinear Model Predictive Control



Desirable MPC Features

- **Multivariable compensation**
 - No pairing of input & output variables required
- **Constraint handling capability**
 - Input & output constraints explicitly include in controller calculation
- **Model flexibility**
 - A wide variety of linear dynamic models can be accommodated
- **Receding horizon formulation**
 - Allows updating of model predictions with measurement feedback
- **On-line implementation**
 - Simple & robust quadratic program
- **Would like to retain these features in nonlinear extension**

Nonlinear Model Predictive Control

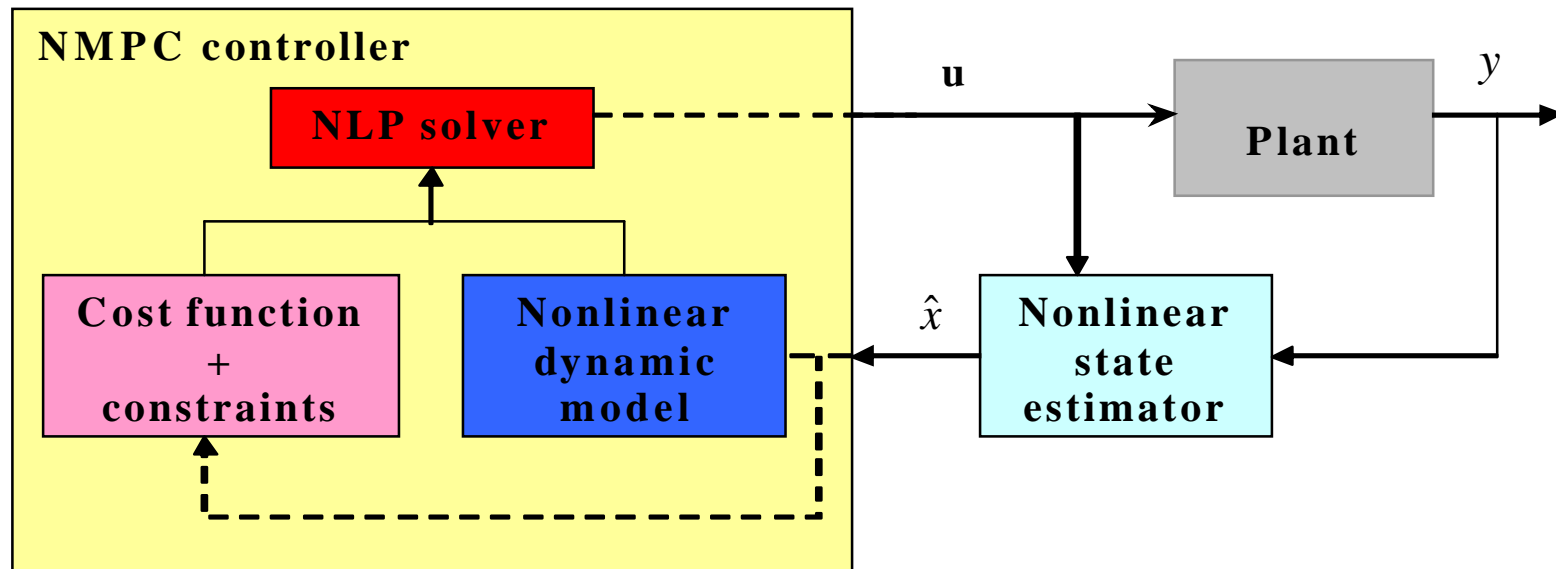

- Nonlinear model
 - Better prediction accuracy than linear model
 - Much more difficult to obtain
- Nonlinear program (NLP)
 - Necessitated by nonlinear model
 - More difficult to implement than LMPC
- Nonlinear state estimator
 - Necessary to generate unmeasured state variable



Nonlinear Process Modeling

- First-principle models
 - Requires understanding of process fundamentals
 - Derived from conservation principles
 - Parameters obtained from literature & estimation
 - Most common approach for NMPC
 - Profit NLC (Honeywell)
- Empirical models
 - Artificial neural networks, NARMAX models, etc.
 - Highly overparameterized & data intensive
 - Poor extrapolation capabilities
 - Suitability for NMPC being demonstrated
 - Apollo (Aspen Technology)
- Development of accurate, computationally efficient nonlinear models remain a major obstacle to NMPC



NMPC Solution Techniques

- Sequential solution
 - Iterate between NMPC optimization & model solution codes
 - Inefficient & non-robust for large problems
- Simultaneous solution
 - All discretized model variables posed as decision variables
 - Produces large-scale NLP problems
 - Routinely applied to low-dimensional process models
 - Moderate size problems solvable with commercial codes
 - Limited by problem size
- Multiple shooting
 - Hybrid of the sequential & simultaneous methods
 - Promising method under development

Model Discretization

- Fundamental model
 - Nonlinear differential-algebraic equations (DAEs)
 - Must be posed as algebraic constraints for NLP solution
 - Requires discretization in time
 - Many methods available
- Orthogonal collocation
 - Highly accurate discretization method
 - Model equations approximated at fixed collocation points
 - Difficult to approximate sharp solutions
 - Produces dense Jacobian matrix

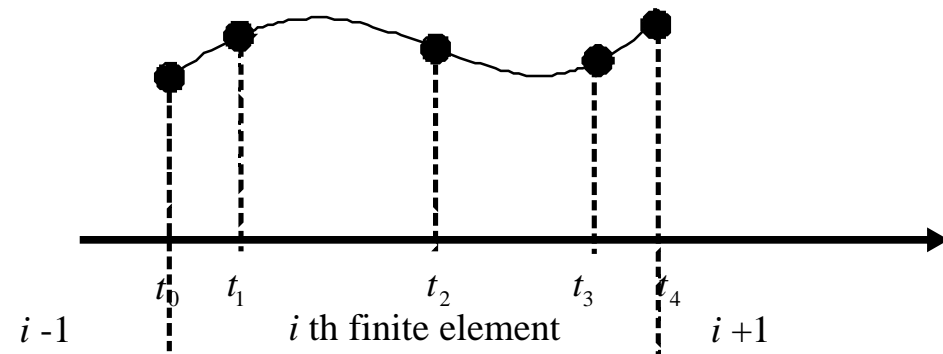

- Finite elements
 - Convenient method for NMPC
 - Divide prediction horizon into N finite elements
 - Place n collocation points in each finite element
 - Accurate & efficient



Simultaneous NMPC Formulation

- Basic elements

- Quadratic objective function
- Bounds on input & output variables
- Nonlinear algebraic equation constraints arising from model discretization
- Yield a nonlinear programming (NLP) problem

- NLP characteristics

- Many decision variables & constraints
- Computationally difficult
- Non-convex à existence of local minima
- Sensitive to equation & variable scaling
- Convergence not guaranteed

$$\text{Min } f(X)$$

$$\text{St. } g(X) \leq 0$$

$$h(X) = 0$$

$$X^L \leq X \leq X^U$$



Representative NMPC Products

Profit NLC

- Developed jointly by Honeywell and PAS Inc. & marketed by Honeywell
- Based on fundamental nonlinear models
- State estimation strategy not described
- Most reported applications to polymer processes
- Basell, British Petroleum, Chevron Phillips, Dow

Apollo

- Developed & marketed by Aspen Technology
- Based on empirical nonlinear models of gain-time constant-delay form
- State estimation performed with extended Kalman filter
- Designed for polymer processes
- Industrial applications underway

Process Perfecter from Pavilion Technologies & Rockwell Automation



Summary – Part 2

- Nonlinear model predictive control (NMPC) is extension of LPMC based on nonlinear dynamic models & optimization
- NMPC offers the potential for improved performance when applied to highly nonlinear processes
- The most widely accepted NMPC approach is based on fundamental model discretization & simultaneous solution
- Commercial NMPC products are available & have been successfully applied to polymer processes
- A major challenge to successful NMPC application to other processes is real-time implementation

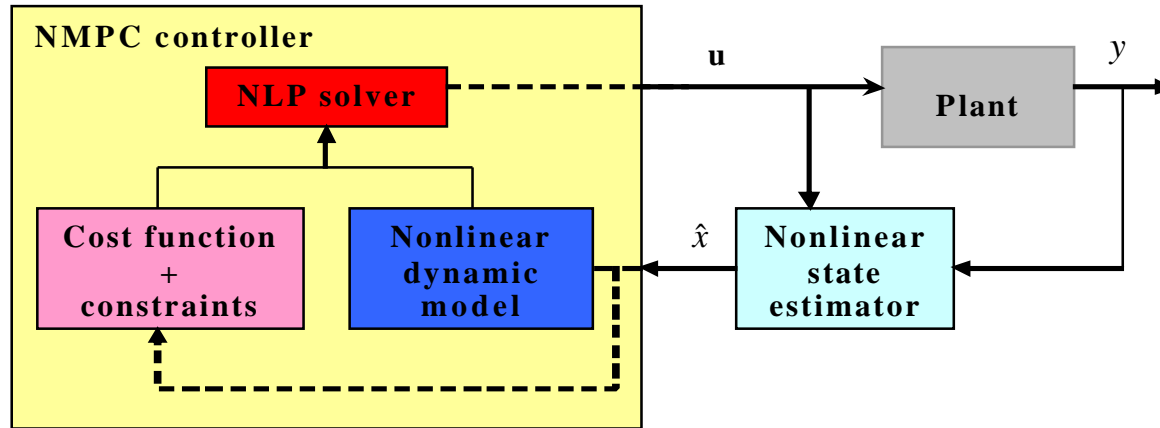

3. Real-Time Implementation Issues



NMPC Problem Size

- Simultaneous solution approach
 - Every state variable at every discretization point is treated as a decision variable
 - Typically produces a large NLP problem
- Problem size determined by:
 - Order of the original dynamic model
 - Number of discretization points
 - Prediction & control horizons
- On-line implementation
 - Requires repeated solution of NLP problem at each sampling interval
 - Real-time implementation can be non-trivial



Real-Time Implementation

- NMPC requires on-line solution of a large, non-convex NLP problem at each sampling interval
 - Typical industrial sampling intervals ~1 minute
 - Controller must reliably converge within the sampling interval
- Potential problems
 - Controller converges to a poor local minimum
 - Controller fails to converge within the sampling interval
 - Controller diverges
- Real-time implementation techniques that mitigate these problems are essential
 - Not a focus of typical academic studies
 - Not openly reported by NMPC vendors & practitioners



Controller Design Model

- Simultaneous solution method
 - Well suited for processes that can be described by nonlinear models of moderate order (<50 DAEs)
 - Yield reasonably sized NMPC problems (~10,000 decision variables)
 - Directly applicable to most polymer reactor models
 - Distillation column models are problematic due to their high order
- Nonlinear model order reduction
 - Reduce model order while retaining the essential dynamical behavior
 - Few generally applicable methods are available
 - Single perturbation analysis, proper orthogonal decomposition
 - Typically method must be customized to specific process



Model Discretization

- Orthogonal collocation on finite elements
 - Divide prediction horizon into N finite elements with each finite element corresponding to a sampling interval
 - Place n collocation points in each finite element
 - Typically use large N (~ 100) and small n (< 5)
- Prediction horizon
 - Chosen according to the steady-state response time
 - Dynamics change slowly near end of prediction horizon where the inputs are held constant
- Finite elements of non-equal length
 - Use regularly spaced elements over control horizon
 - Use increasingly wider spaced elements after the control horizon
 - Reduces number of discretization points
 - Implementation problem dependent



NLP Solution Code

- Wide variety of NLP codes are available
 - Successive quadratic programming (NPSOL)
 - Generalized reduced gradient methods (CONOPT)
 - Interior point methods (IPOPT)
- Problem dependence
 - Particular codes work better for specific problems
 - General guidelines available but successful implementation requires match of NLP problem and code
 - Typically must be determined by trial-and-error experimentation & code tuning
 - Facilitated by general purpose optimization modeling tools such as AMPL and GAMS
 - Problem/code matching reduces the number of iterations and/or the time per iteration



Derivative Information

- **First-order and second-order derivatives**
 - Required for discretized model & constraint equations with respect to the decision variables
 - The Jacobian & Hessian matrices tend to be large & ill-conditioned
 - Can be numerically calculated by finite difference
 - Very time consuming & subject to numerical errors
- **Analytical derivative calculation**
 - Derivative exactly calculated from analytical formulas
 - Facilitated by automatic differentiation capabilities of optimization modeling languages (AMPL)
 - Improves NLP code efficiency & robustness



Controller Initialization

- NLP solution
 - An initial guess of the solution X_k^0 is required at each sampling interval k
 - Convergence properties depend strongly on X_k^0
 - Need to generate a good X_k^0 near the optimal solution
- Warm start strategy
 - Use converged solution from previous iteration X_{k-1} to generate X_k^0
 - Set $X_{k+j|k}^0 = X_{k+j|k-1}$ and $X_{k+p|k} = X_{k+p-1|k-1}$
 - Reduces the number of NLP iterations
- Caveats
 - Not guaranteed to produce fast convergence
 - Not effective immediately following setpoint or disturbance change

$$\begin{aligned} \text{Min} \quad & f(X) \\ \text{St.} \quad & g(X) \leq 0 \\ & h(X) = 0 \\ & X^L \leq X \leq X^U \end{aligned}$$



Summary – Part 3

- The NMPC simultaneous solution method yields large & non-convex NLPs
- The NLP must be solved efficiently & robustly during each sampling interval
- Modifications of the basic NLP strategy are needed to facilitate real-time implementation
 - Nonlinear model order reduction
 - Customized model discretization strategies
 - Matching of discretized model with NLP code
 - Analytical derivative calculation
 - Warm start strategies

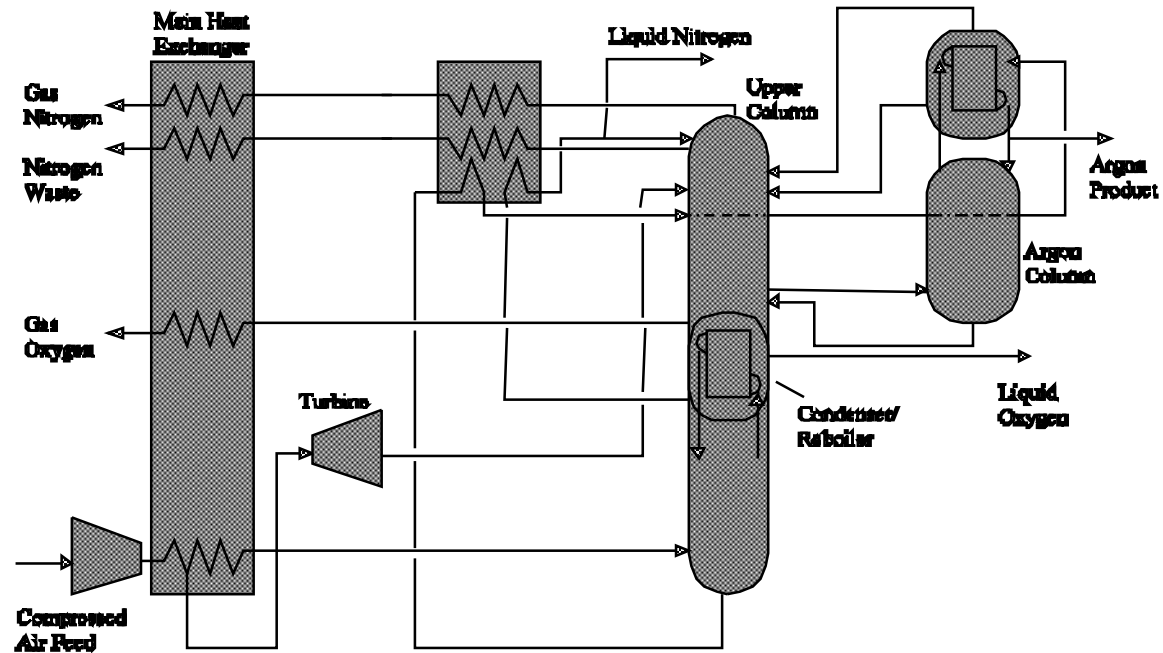

4. Nonlinear Control of an Air Separation Column



Fundamental Model of Upper Column

- Assumptions
 - Similar to those used for Aspen model development
 - Also assume negligible vapor phase holdups & linear pressure drop across column
- Equations
 - Dynamic mass & component balances
 - Steady-state energy balances
 - Non-ideal vapor-liquid equilibrium different from Aspen model
 - Reboiler level & overhead pressure controllers
 - Lower column effect on upper column described by empirical linear models
- Dimensionality
 - 180 differential equations & 137 algebraic variables
 - About 1900 intermediate variables for thermodynamic model



Standard NMPC Formulation

- Problem characteristics
 - 2 output & 5 input variables
 - 317 state variables & 1900 thermodynamic variables
 - Discretization produces ~500,000 decision variables
 - Very challenging NLP problem that pushes the state-of-the-art
 - Application of simultaneous solution method have been limited to open-loop dynamic optimization
- Possible solutions
 - Develop customized solution techniques that exploit problem structure
 - Develop real-time implementation strategies



Real-Time Implementation

- Use compartmental model
 - Jacobian & Hessian matrices become more sparse
 - Significantly reduces the time for each NLP iteration
- Allow finite elements to have non-uniform lengths
- Optimize the NLP solver options
 - Requires code expertise
 - Significantly reduces the number of NLP iterations
- Use warm start strategy
- Calculate derivative information analytically
- Less important strategies
 - Scale the variables & constraint equations
 - Implement setpoint changes as ramps or exponentials



Compartmental Modeling

- Fundamental idea
 - Divide column into several sections (compartments)
 - Only describe the overall (slow) dynamics of each compartment with a differential equation
 - Describe the individual stage (fast) dynamics with algebraic equations
- Compartmental model characteristics
 - Provides perfect steady-state agreement with fundamental model
 - Fewer differential equations but more algebraic equations
 - Highly accurate if a sufficient number of compartments is used
- Advantages for NMPC
 - Compartmentalization yields a more sparse model structure that can be exploited by NLP codes



Upper Column Compartmentalization

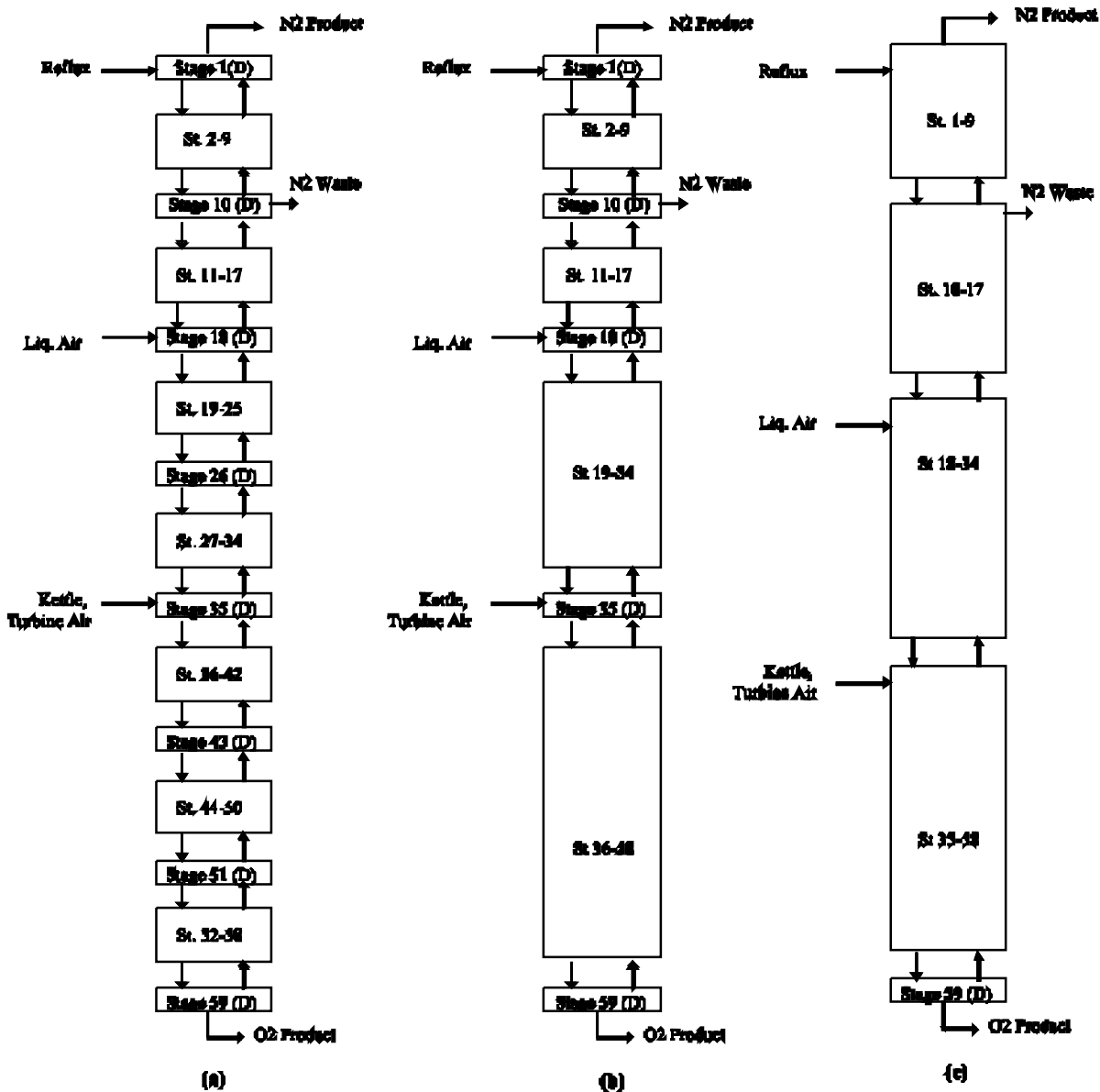

| Model | ODEs | AEs |
|----------------|------|-----|
| Fundamental | 180 | 137 |
| 15 compartment | 48 | 269 |
| 9 compartment | 30 | 287 |
| 5 compartment | 18 | 299 |

Comparison of Compartmental Models

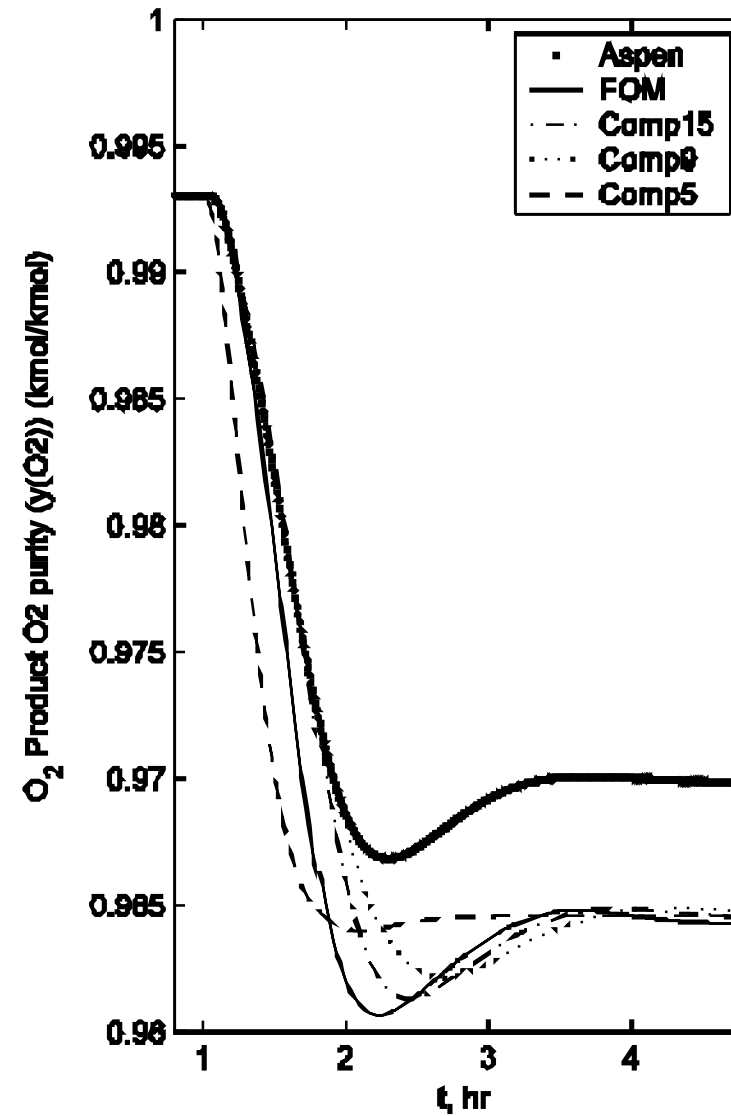
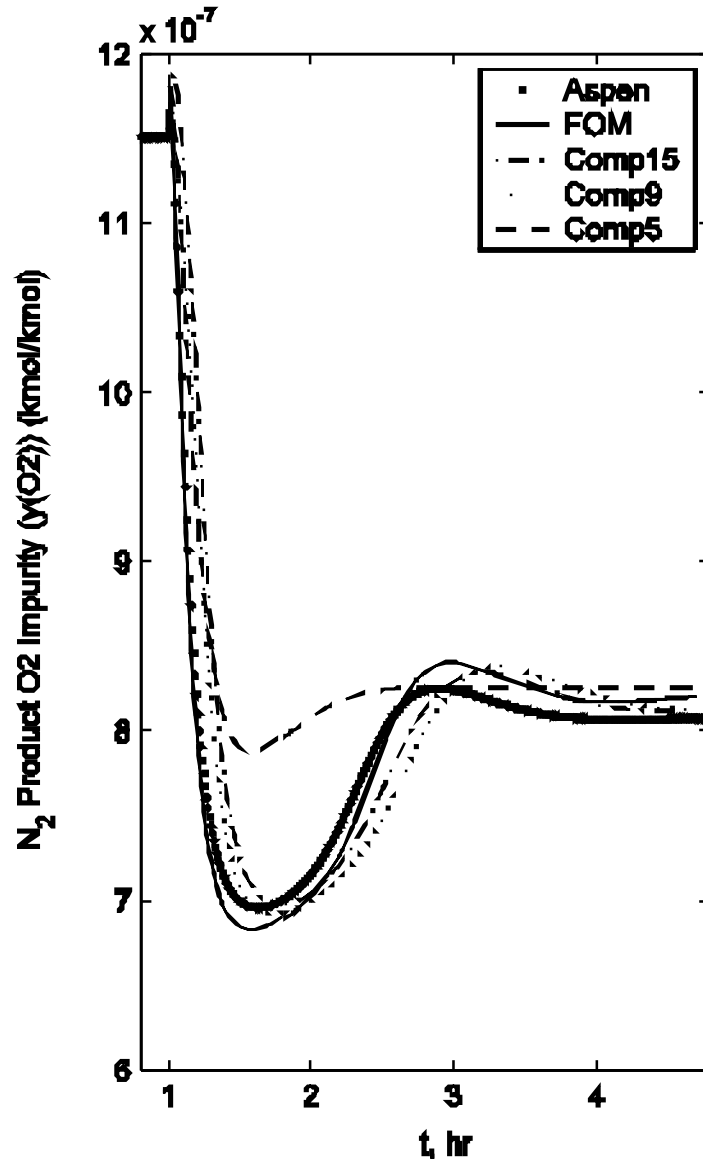



NMPC Formulation for Upper Column

- Largely unchanged from LMPC formulation
 - Sampling time = 2 min
 - Prediction horizon = 4.3 hr
 - Control horizon = 20 min
- Discretized dynamic model equations
 - Compartmental model
 - Nonlinear equality constraints
- NLP solution
 - Interior point code IPOPT within AMPL
 - Less success with popular solver CONOPT
 - AMPL coupled to fundamental model in MATLAB

NMPC Formulation for Upper Column

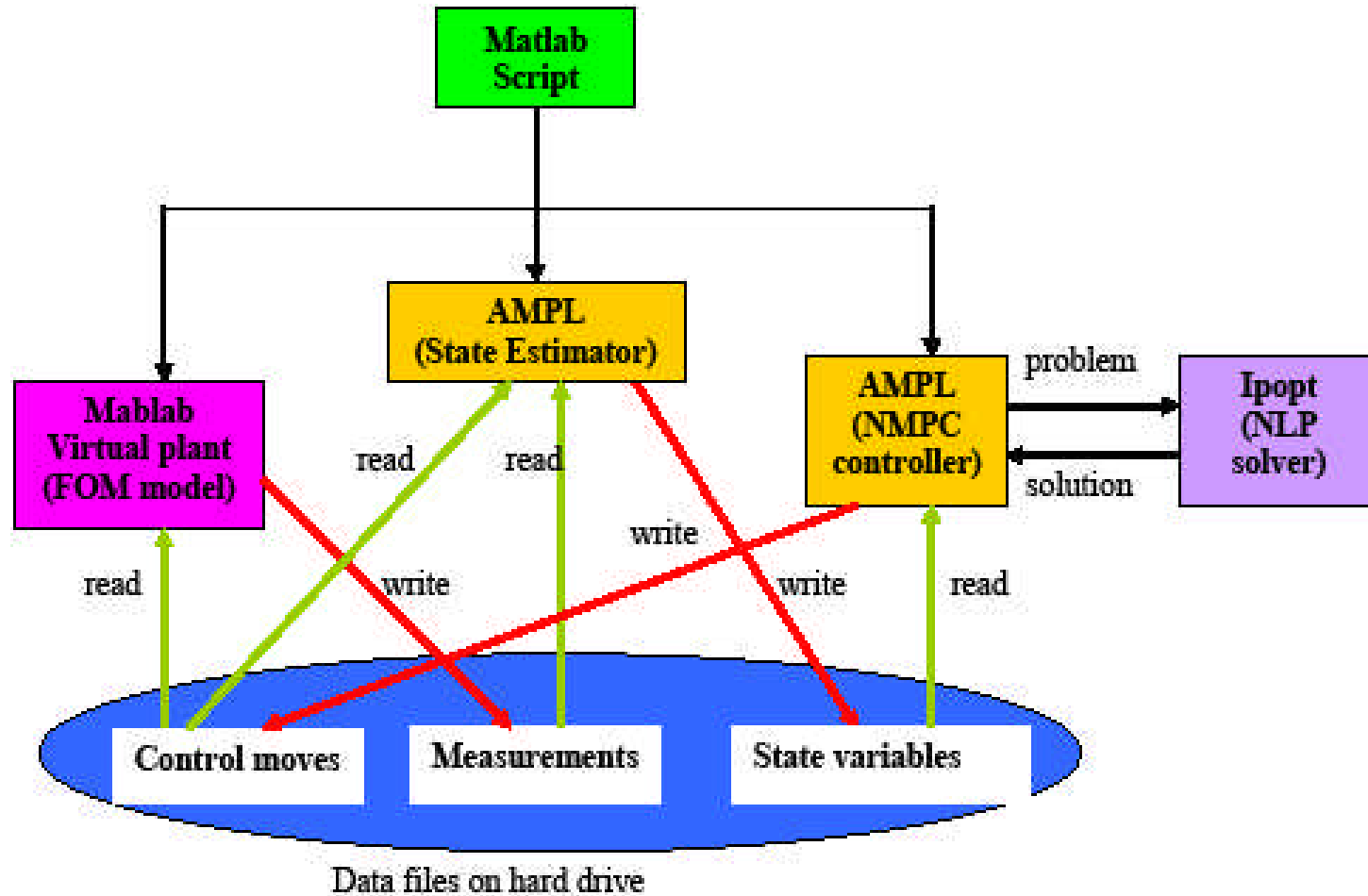



Reducing Real-Time Computation

Initial CPU time ~40 min/iteration

- I. Use finite elements with non-uniform lengths
- II. Use compartment model
- III. Optimize the NLP solver options
- IV. Analytically calculate the Jacobian & Hessian matrices
- V. Scale the variables & constraints
- VI. Use warm start strategy
- VII. Implement setpoint changes as ramps

Final CPU time ~2 min/iteration

12780 decision variables & 12730 constraints

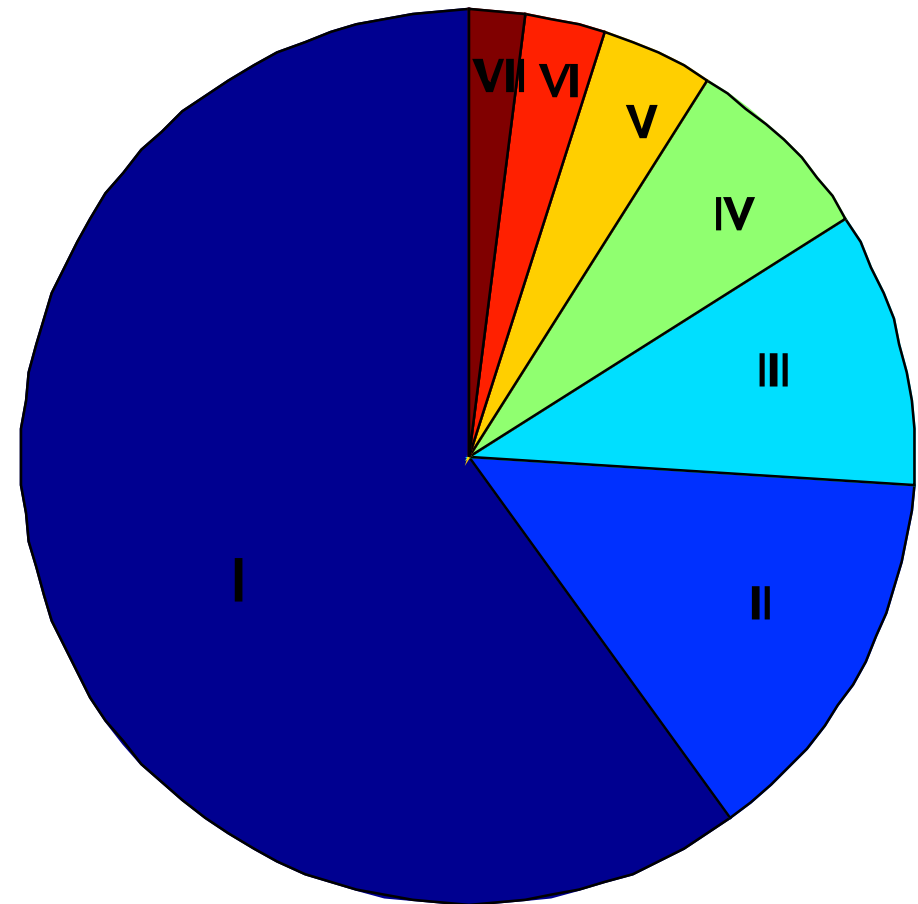

Contribution of each strategy to reduction in worst case NMPC CPU time



15% Production Increase

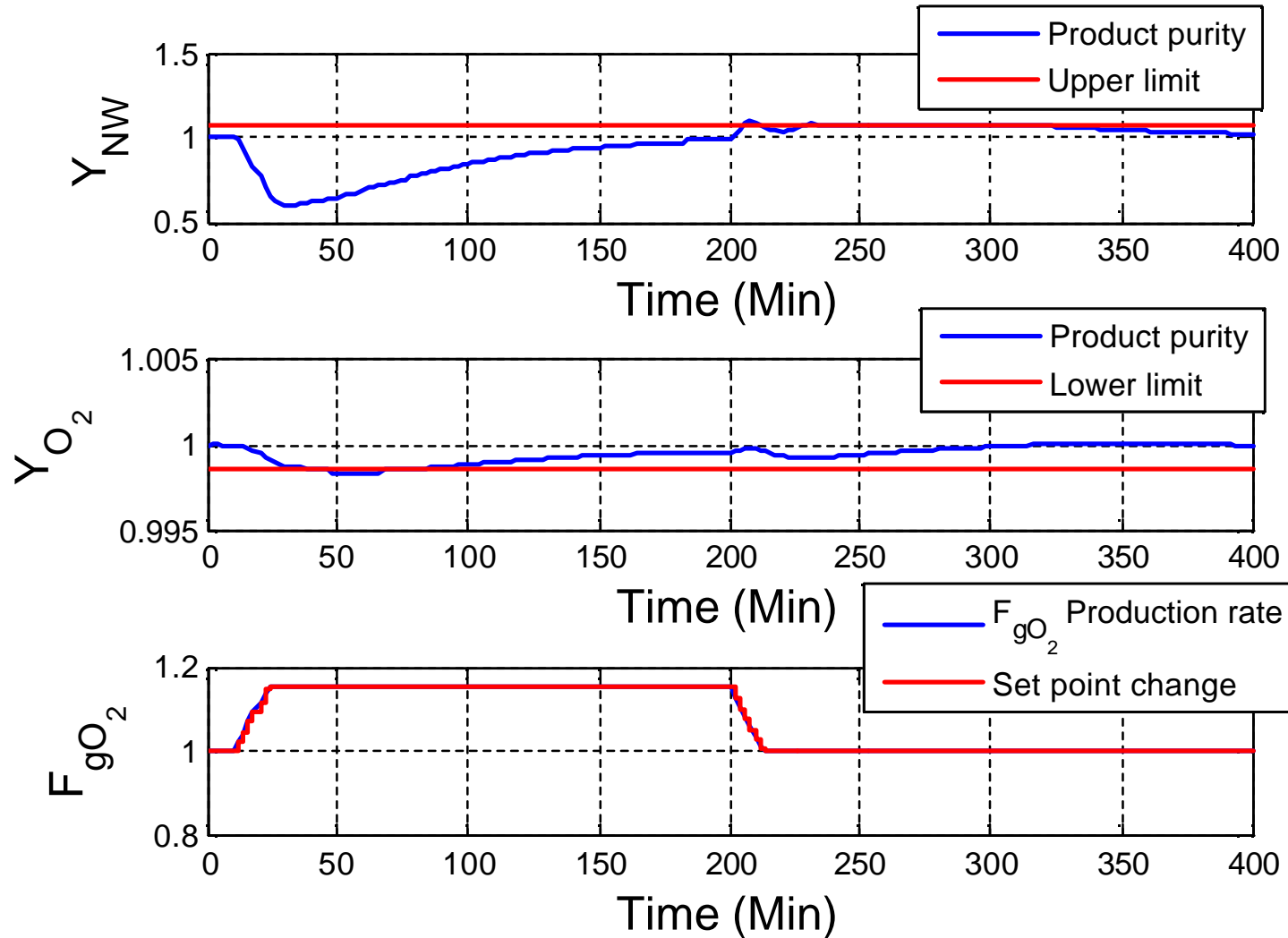



15% Production Increase

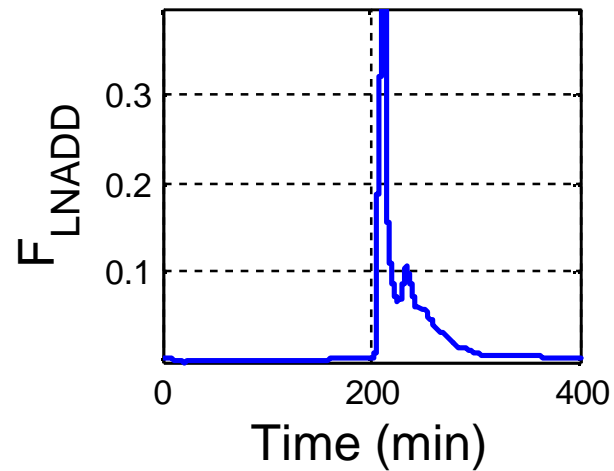
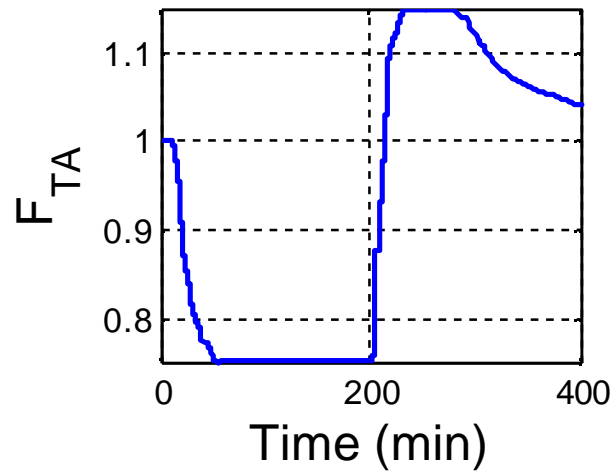
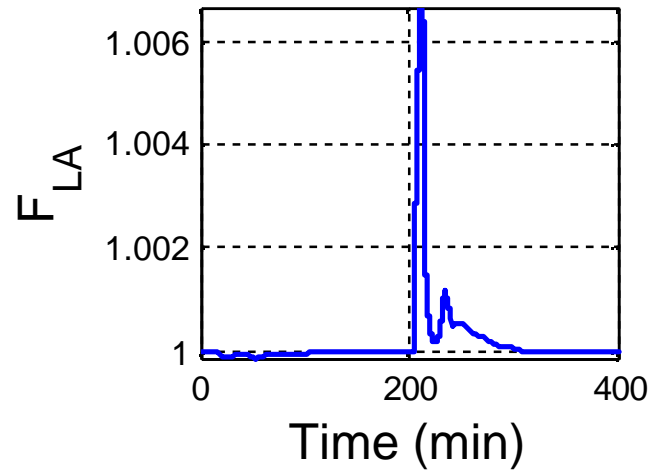
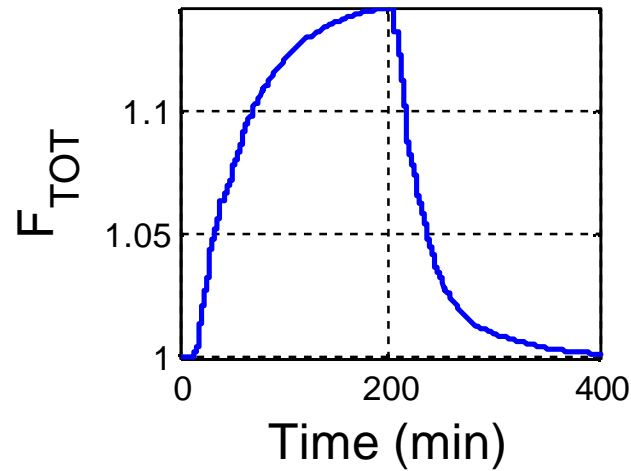



30% Production Decrease

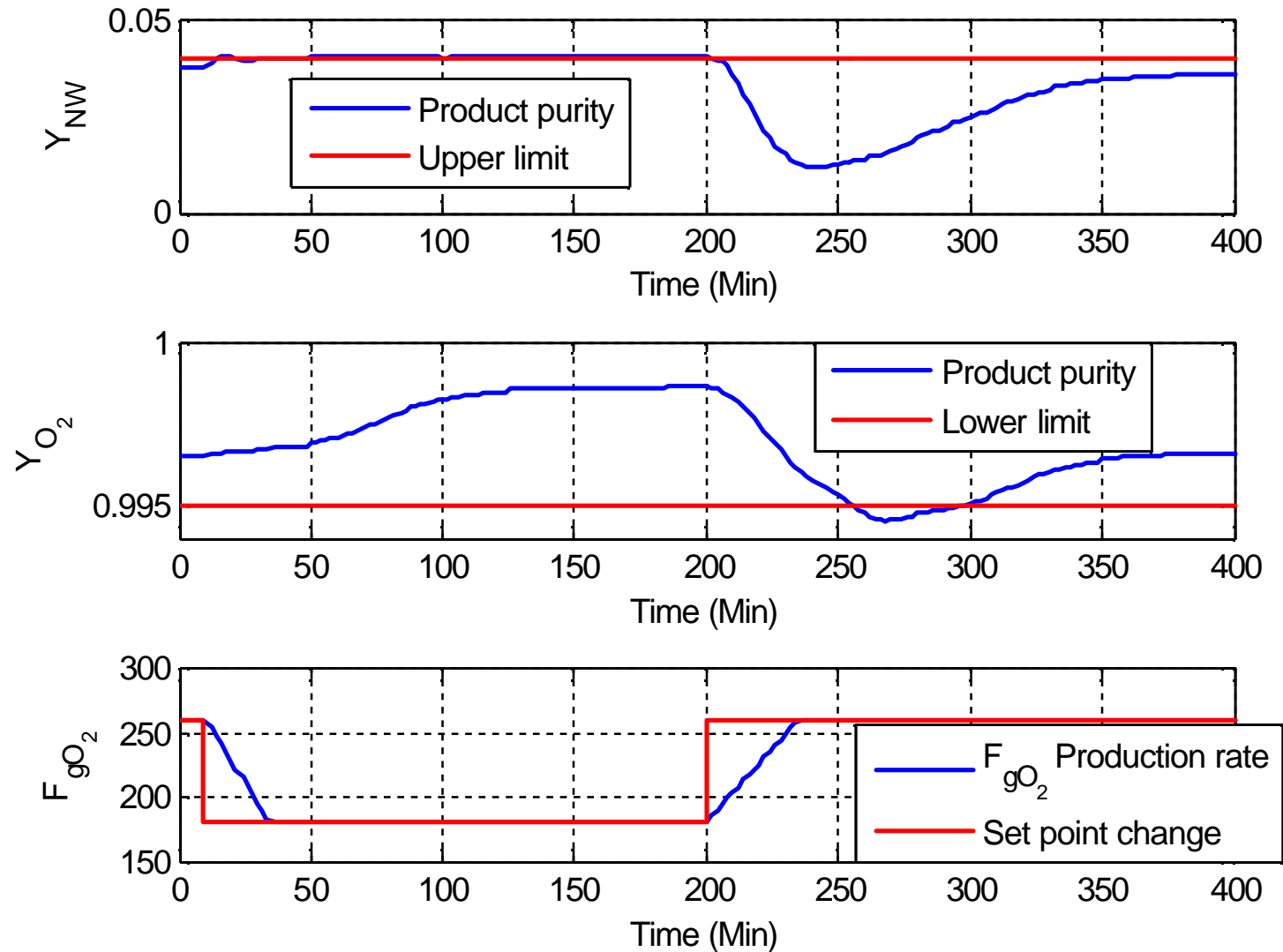

30% Production Decrease

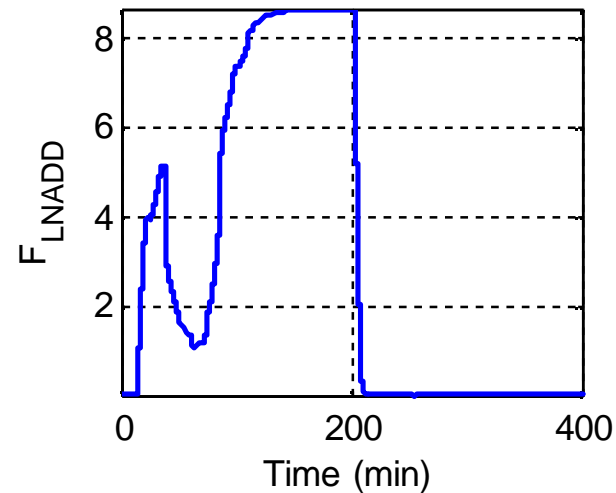
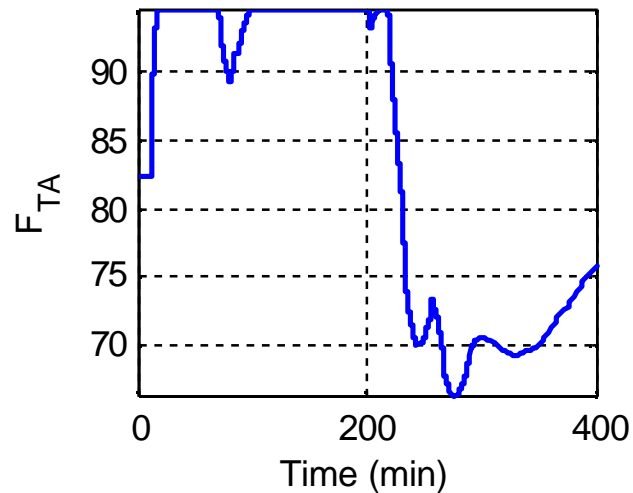
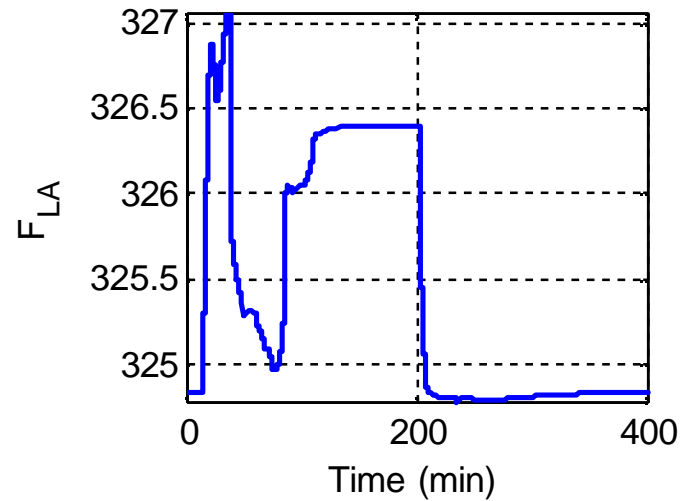
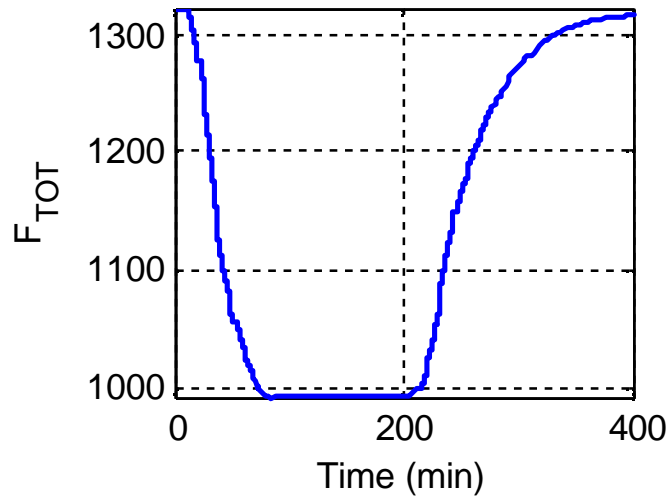

NMPC CPU Times per Iteration

15% Production Increase

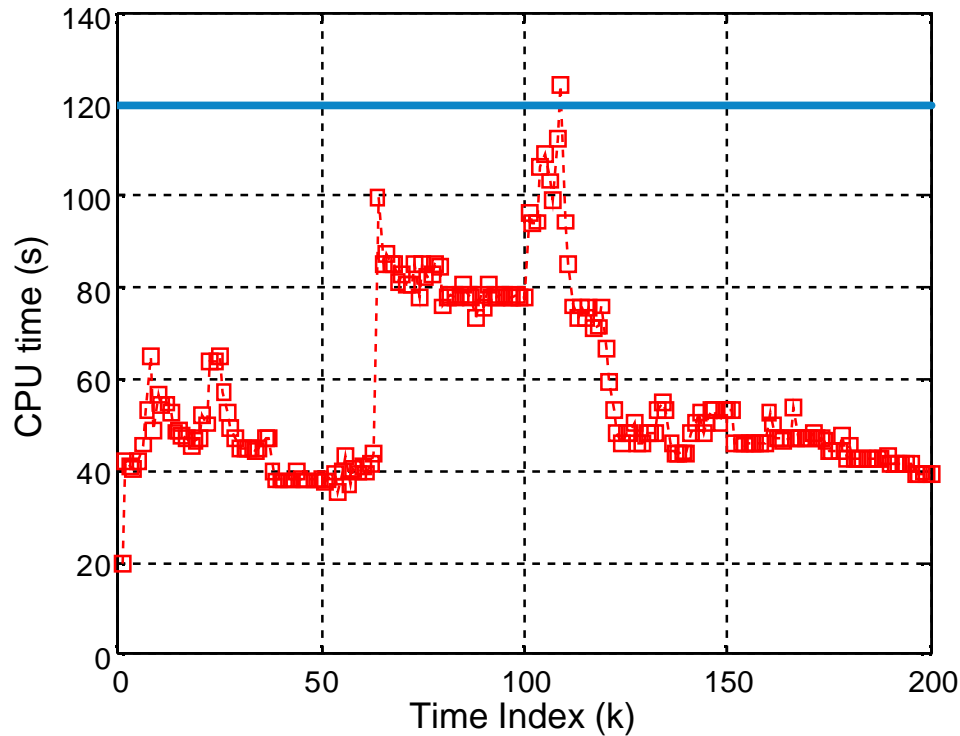

30% Production Decrease

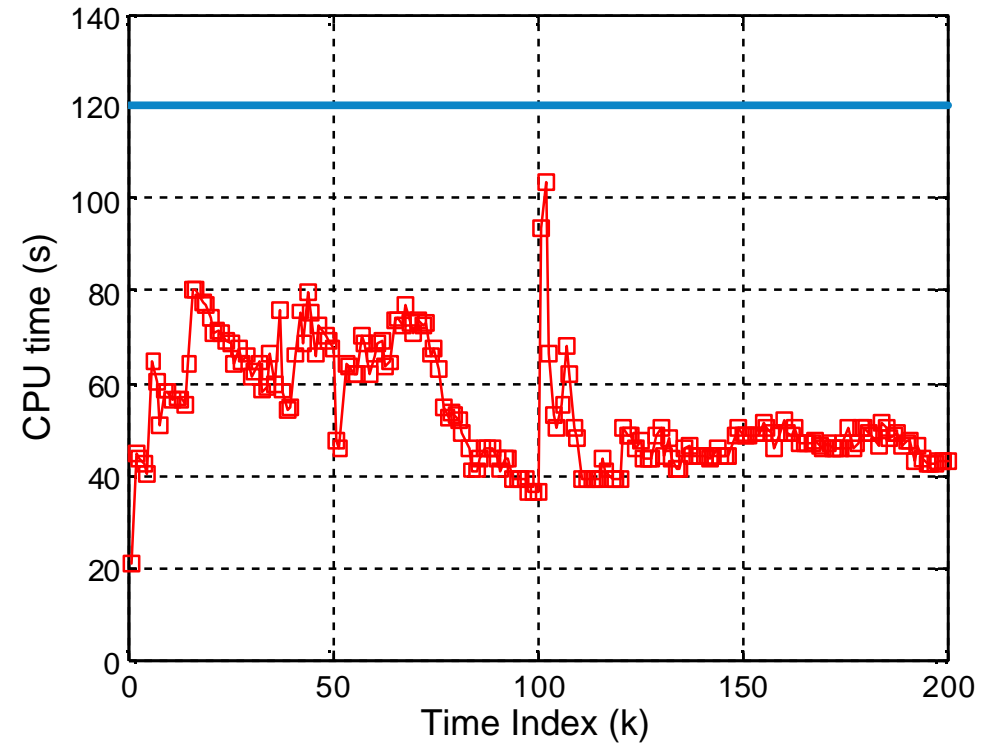



Summary – Part 4

- Direct application of NMPC to the air separation column yielded a very large NLP problem not suitable for real-time implementation
- The combination of reduced-order modeling and several real-time implementation strategies reduced computation time by 2000%
- NMPC provided good performance for large production rate changes that proved problematic for LMPC
- NMPC development required considerable time and effort



Final Comments

- NMPC is a promising technology for nonlinear plants subject to large dynamic changes
- Availability of an accurate nonlinear model is paramount
- Real-time implementation strategies are often necessary for reducing computation
- Nonlinear receding horizon estimation is a promising approach for generating estimates of unmeasured state variables (not shown here)
- The time and effort required for NMPC development and maintenance must be justified