

Is a Symbolic Math Program for You?

Lee R. Partin

Voridian

a Division of Eastman Chemical Company

Copyright Eastman Chemical Company 2004

Abstract

I find numerous applications for symbolic math software in my chemical engineering career. I initially purchased Maple[®] by [MapleSoft](#) a decade ago when I purchased my first PC for home, so I have many examples that I could discuss. Maple performs symbolic and numeric mathematics for a wide range of tasks. It also has extensive graphic functions and an integrated programming environment with open architecture. Mathematica[®] by [Wolfram Research](#) is a good alternative to Maple. I teach seminars on modeling topics within the CPI. It's easy to promote seminars on applying Microsoft Excel[®] to engineering tasks but I see very few engineers using Maple or Mathematica. Maybe, I will be able to pique your interest enough that you will try it. I use it for many tasks and it has enabled me to perform projects that I would not have done otherwise.

Do You (Did You) Enjoy Math?

I decided to be a chemical engineer due to because of combined interests in mathematics and chemistry. The Maple software allowed me to regain my proficiency in math. It lets me tackle the development of more complex chemical processing models. It is a 'calculator' for algebraic manipulations, trigonometry or calculus operations. Here are some examples from Maple:

$$\int_0^a x^2 \sin(x) dx$$

has the solution

$$-a^2 \cos(a) + 2 \cos(a) + 2 a \sin(a) - 2$$

$$\frac{d}{dx} \left(\sqrt{x} e^x \right)$$

has the solution

$$\frac{e^x}{2\sqrt{x}} + \sqrt{x} e^x$$

The equations for a countercurrent heat exchanger may be solved for the heat duty and outlet stream temperatures. The solution is simplified in terms of two dimensionless

Symbolic math solves for precise answers and formulas. It would be very challenging to accurately solve for the sum of cubes in other software over such a large domain. Even given the formula from Maple, Excel gives 2.50000000005E+47 as the approximate solution to the summation. I surely would not want to wait on an Excel macro to perform the for loop from 1 to a trillion and it would have extensive round off errors. Maple does the calculation rapidly since it knows the formula and performs precise calculations.

You may also request numerical solutions to desired accuracy. Suppose you want to know π to 200 digits:

```
evalf(Pi, 200);
```

```
3.141592653589793238462643383279502884197169399375105820974944592307816406286208\  
998628034825342117067982148086513282306647093844609550582231725359408128481\  
1174502841027019385211055596446229489549303820
```

I provide these examples to show a wide range of the mathematics available in Maple. It has much more.

Where Maple Applications Fit into My Career

I write engineering models with different software depending on the requirements of the task. My common options are:

- Simple calculations tend to be performed as Excel spreadsheets. Mathcad[®] (<http://www.mathsoft.com>) is preferred when the task involves unit conversions within the equations.
- Stochastic modeling is typically performed using the @RISK add-in to Excel (<http://www.palisade.com>)
- As the modeling task becomes more complicated, I routinely document the step-by-step model derivation using Mathcad or Maple. Mathcad provides a white board where you combine word processing, typeset formulas, calculations and plots. It even includes an interface to some of the Maple functions for use in formula derivations.
- Many times, I port the models from Mathcad or Maple into Excel by writing a COM object in Compaq Visual Fortran Professional (<http://h18009.www1.hp.com/fortran/index.html>) and linking it to Excel via Visual Basic for Applications. This gives the advantages of fast execution, spreadsheet capabilities and the distribution of the model to a wide range of users. I sometimes write the user interface within C# instead of a spreadsheet.
- I apply specialized software where appropriate such as Aspen Plus[®] (<http://www.aspentech.com>) for chemical plant simulations.
- I have written several Maple applications for specialized tasks. Its integrated programming environment has been my first and sometimes only choice for several of my engineering applications.

The next sections give examples of cases where Maple was my best selection for writing the application.

Pinch Analysis

I have been interested in various process synthesis topics throughout my career. It was easy to write the pinch analysis calculations and graphics within Maple. C# would be a good platform for me to write the application now but I did not have a good alternative at the time I wrote the pinch analysis application.

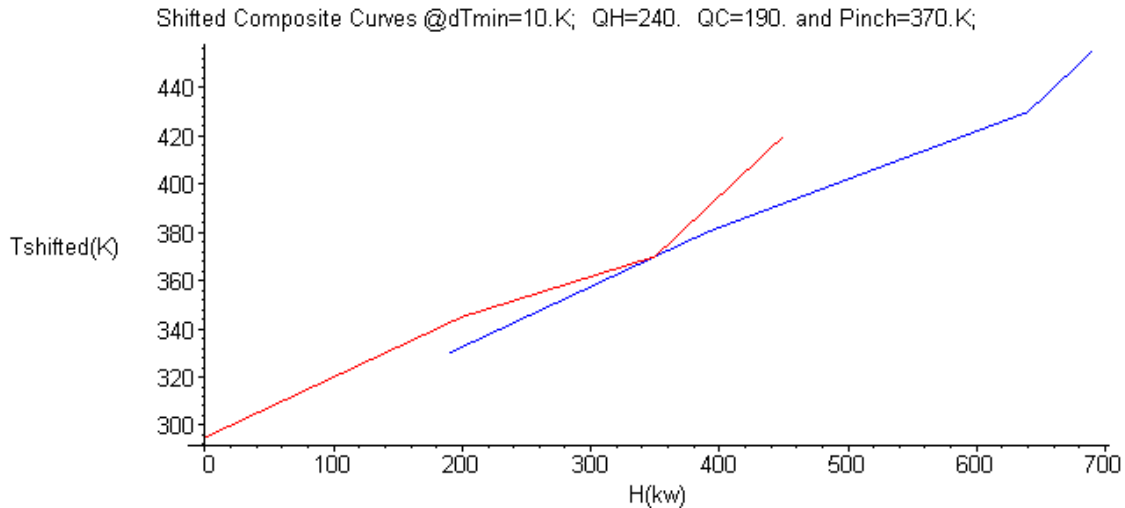

Combinatorial Analysis

Professor L. T. Fan introduced me to the great world of combinatorial analysis applied to chemical plant synthesis (Friedler et al, 1993; Friedler et al, 1995; Partin, 1998). He is the 2003 recipient of the CAST Computing in Chemical Engineering Award for his extensive accomplishments in chemical engineering computing. I turned to Maple as my only reasonable choice for programming the combinatorial algorithms. Maple easily handles the complex data structures, list and set functions, and programming logic of the algorithms. You enter data to define the process feeds, products and potential unit operations for the process synthesis. The technique first finds the maximal structure from the process information. If a maximal structure exists in the information, then a second algorithm finds all feasible flowsheets within the maximal structure. Here is the Maple code for the first algorithm to find the maximal structure. It calls other functions that were easy to program in Maple.

```
# Program MSG algorithm,
MSG:=proc (OpSet, RM, Pr)
  local i, item, opset, Mat, o, r, p, m, ox;
  opset:=OpSet minus phi_minus(RM, OpSet);
  Mat:=Psi_minus(opset) union Psi_plus(opset);
  r:=Psi_minus(opset) minus (Psi_plus(opset) union RM);
  if nops(r) > 0 then
    while r <> {} do
      item:={op(1, r)};
      Mat:=Mat minus item;
      o:=phi_plus(item, opset);
      opset:=opset minus o;
      r:=(r union (Psi_plus(o) minus Psi_plus(opset))) minus item;
    od;
  end if;
end proc;
```

```

fi;
if (Pr union Mat) <> Mat then
  lprint(`Error: No maximal structure exists!`);
  RETURN(`No maximal structure exists!`);
fi;
p:=Pr;
m:={};
o:={};
while p <> {} do
  item:={op(1,p)};
  m:=m union item;
  ox:=phi_minus(item,opset);
  o:=o union ox;
  p:=(p union Psi_minus(ox)) minus (RM union m);
od;
m:=Psi_minus(o) union Psi_plus(o);
[m,o];
end:

```

I still do not have an easy alternative to Maple for this application. I could do it within C# but it would be a major effort. Maple makes it so easy to create complex data structures. For example, the opset variable in the MSG procedure is a set of unit operations. Each unit operation is a list containing the set of feeds and the set of products. Here is an example return value of [m,o] from the MSG procedure:

```

maximal_structure := [{ O, D, F, E, L, G, C, H, J, B, T, A, K, M, W }, {
  [{ F, T }, { A }], [{ B }, { D, W }], [{ C }, { G, T }], [{ D, G }, { O }],
  [{ O }, { E, H }], [{ G, K }, { L }], [{ A }, { C, B }], [{ F, B }, { J }],
  [{ C, K }, { M }], [{ H }, { C, B }], [{ J }, { K, W }], [{ L }, { E, H }],
  [{ M }, { E, H }]}]

```

Maple also has a network package that I used to analyze the chemical plant flowsheets:

- find the number of material flow loops
- identify material balance constraints around sections of the flowsheet
- prepare a file containing flowsheet information for automated plotting within Microsoft Visio®. The Maple application writes a text file containing the flowsheet data (streams, equipment, icon selections, connectivity and pathways through the flowsheet). A VBA macro within Visio reads the information and automates the drawing tasks.

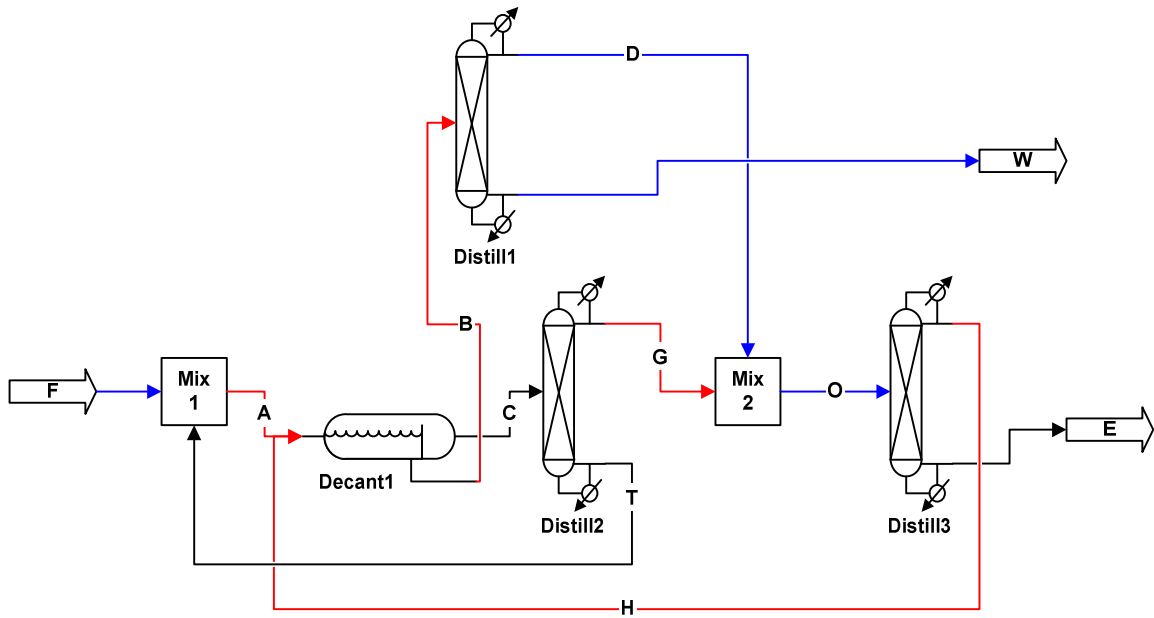

Ternary Separations

Binary azeotropes are sometimes broken via the addition of a third component and a combination of processing steps (mixing, distilling, decanting and extraction). It is possible to predict the distillation behavior of ternary systems from knowledge of the azeotropes and boiling temperatures. I programmed the calculations within Maple. The ethanol-water azeotrope may be broken using toluene. There are three distillation boundaries in the 222-m residue curve map for ethanol-water-toluene. The 222 denotes that each binary pair has a minimum boiling azeotrope and m denotes a minimum boiling ternary azeotrope.

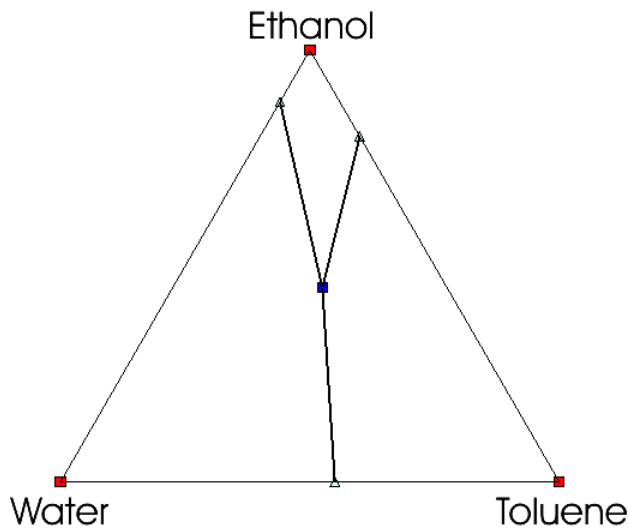

I combined the combinatorial algorithms from the previous example with distillation residue curve map software (Peterson and Partin, 1997) to obtain a synthesis tool within Maple. You enter the toolkit of potential unit operations on the ternary diagram.

The T module within the Maple application handles the calculations. The user must enter the material streams (name, type and composition) for consideration in the synthesis task. Compositions are defined by entry of the two component fractions, by stream addition or subtraction, or by intersection of two lines.

```
T:-AddPoint ("F", "Feed", 0.5, 0.5) :
T:-AddPoint ("W", "Product", 0, 1.) :
T:-AddPoint ("E", "Product", 1., 0) :
T:-AddPoint ("t", "Intermediate", 0, 0) :
T:-AddPoint ("A", "Intermediate", F+t, 0.24) :
T:-AddPoint ("B", "Intermediate", 0.375, 0.50) :
T:-AddPoint ("J", "Intermediate", F+B, 0.9) :
T:-AddPoint ("C", "Intermediate", A-B, 0.77) :
T:-AddPoint ("H", "Intermediate", 0.45, 0.25) :
T:-AddPoint ("K", "Intermediate", J-W, 0.3) :
T:-AddPoint ("d", "Intermediate", B-W, 0.3) :
T:-AddPoint ("M", "Intermediate", C+K=E+H) :
T:-AddPoint ("G", "Intermediate", C-t, 0.2) :
T:-AddPoint ("o", "Intermediate", d+G=E+H) :
T:-AddPoint ("L", "Intermediate", G+K=E+H) ;
```

Next, the user defines the process units under consideration by entering the names and related streams.

```
T:-AddUnit ("Mix1", F+t=A) :
T:-AddUnit ("Decant1_a", A=B+C) :
T:-AddUnit ("Distill1", B=d+W) :
T:-AddUnit ("Distill2", C=G+t) :
T:-AddUnit ("Mix2", G+d=o) :
T:-AddUnit ("Distill3_a", o=H+E) :
T:-AddUnit ("Decant1_b", H=B+C) :
T:-AddUnit ("Mix3", F+B=J) :
T:-AddUnit ("Distill4", J=K+W) :
T:-AddUnit ("Mix4", G+K=L) :
T:-AddUnit ("Distill3_b", L=H+E) :
T:-AddUnit ("Mix5", C+K=M) :
T:-AddUnit ("Distill3_c", M=H+E) ;
```

The application finds the maximal structure from the information and shows it on the residue curve diagram.

Flowsheet for Maximal Structure

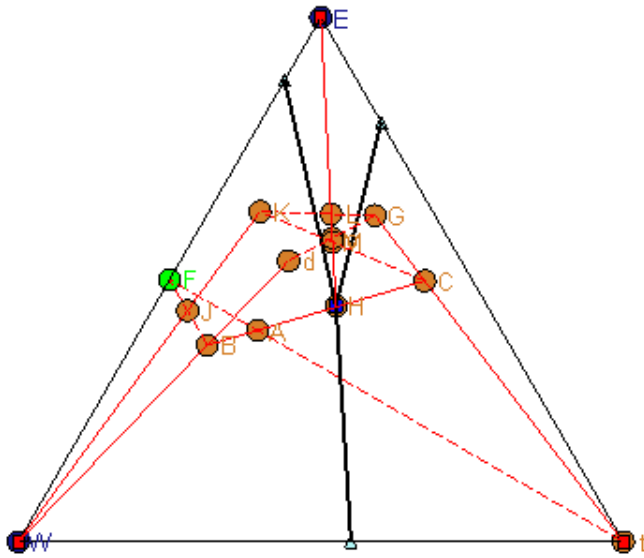

The combinatorial algorithms found seven flowsheets within the maximal structure for separating the feed F into W and E with no by-products.

Flowsheet #1

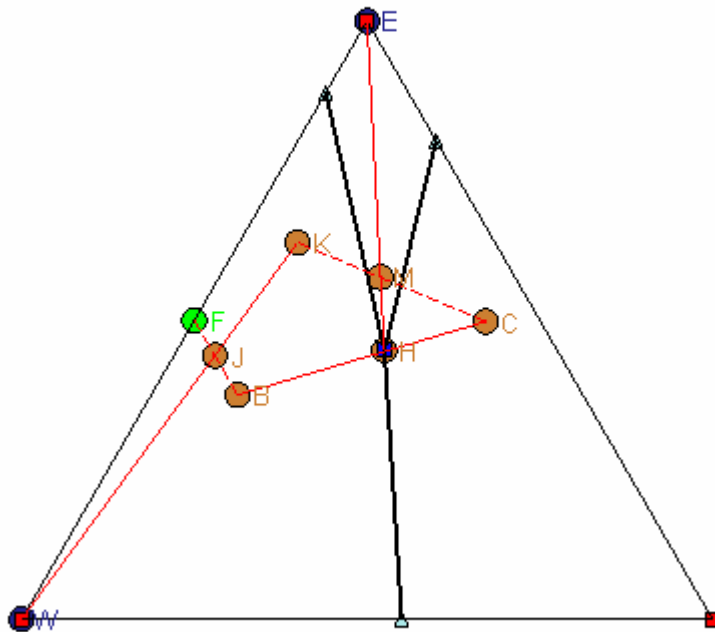

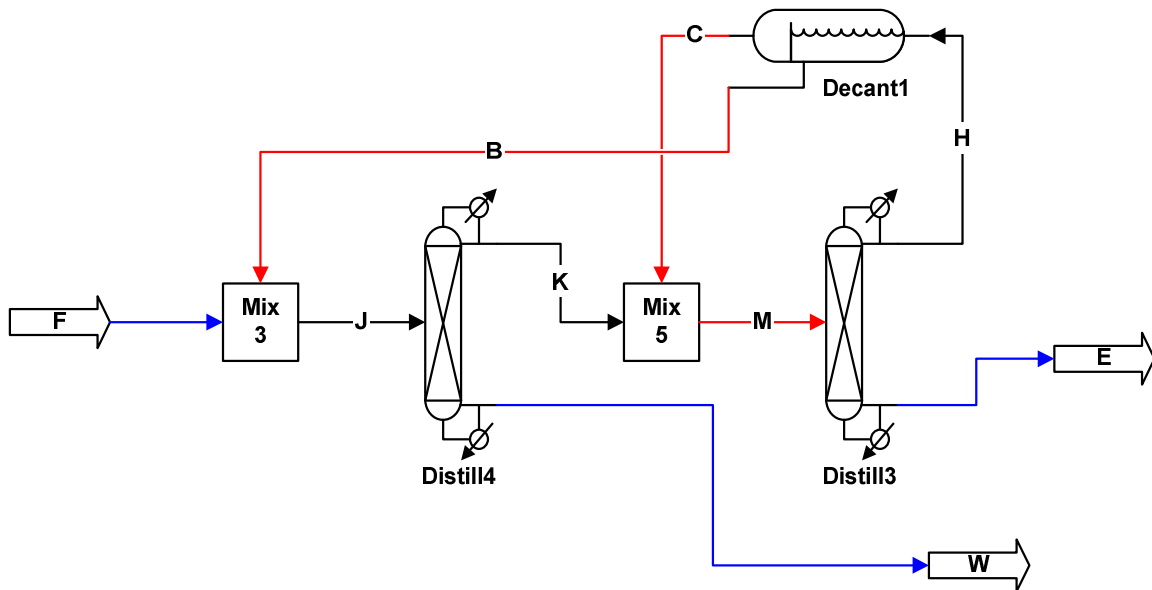

I am very pleased with the capabilities of this Maple distillation synthesis application. It has advanced features that are not available in commercial synthesis software.

Buckingham Π Theorem

The Buckingham Π Theorem is quite interesting to me. I much prefer the application of Π groups in model development instead of the empirical fitting of data to process parameters. Thomas Szirtes studied the theorem extensively and wrote a good book on it (Szirtes, 1997). He developed algorithms for selecting the Π groups. After MapleSoft added the units package to Maple, I wrote a Maple application that automates the selection of Π groups. The capabilities of Maple made it easy to write the application. The module programming feature of Maple has object-oriented features that worked well for this application.

Heat Transfer in a Pipe – Example of Using Maple Application

The rate of heat transfer of a fluid in a pipe is given by $Q = h A \Delta t$

Heat Flow = heat transfer coefficient * area * temperature difference between the fluid and the pipe wall

The heat transfer coefficient is related to six other parameters. The parameter list is:

```

h:=heat_transfer_coefficient: # heat transfer coefficient
rho:=mass_density: # density of the fluid in the pipe
Cp:=specific_heat_capacity: # fluid heat capacity
k:=thermal_conductivity: # fluid thermal conductivity
mu:=dynamic_viscosity: # fluid viscosity
v:=speed: # fluid velocity
Dia:=length: # pipe inside diameter

```

```

GeneratePiTheorem(Case): # create a module called Case
Case:-Initialize(['h'=h, 'rho'=rho, 'Cp'=Cp, 'k'=k, 'mu'=mu,

```

```
'v'=v, 'Dia'=Dia]); # initialize the module with parameters
Case:-Check(); # perform feasibility check
```

$$UnitMatrix = \begin{bmatrix} 0 & -3 & 2 & 1 & -1 & 1 & 1 \\ 1 & 1 & 0 & 1 & 1 & 0 & 0 \\ -1 & 0 & -1 & -1 & 0 & 0 & 0 \\ -3 & 0 & -2 & -3 & -1 & -1 & 0 \end{bmatrix},$$

Fundamentals = [length, mass, thermodynamic_temperature , time],

Parameters = ["h", "rho", "Cp", "k", "mu", "v", "Dia"], *UnitlessParameters* = 0

```
Case:-FindPiGroups(); # find the groups
```

```
labels = [ "h", "rho", "Cp", "k", "mu", "v", "Dia" ],
```

$$PiCoeffs = \begin{bmatrix} 1 & 0 & 0 & -1 & 0 & 0 & 1 \\ 0 & 1 & 0 & 0 & -1 & 1 & 1 \\ 0 & 0 & 1 & -1 & 1 & 0 & 0 \end{bmatrix}$$

The resulting Pi groups are:

```
Case:-PrintPiGroups(); # print the groups
```

$$\left[\Pi_1 = \frac{h \text{ Dia}}{k}, \Pi_2 = \frac{\rho v \text{ Dia}}{\mu}, \Pi_3 = \frac{Cp \mu}{k} \right]$$

The groups are known as the Nusselt number, Reynolds number and Prandtl number.

Reaction Kinetics

Suppose you wanted an application that handled the calculations of reaction kinetics.

The application may need to:

- accept entry of any number of chemical species and chemical reaction steps
- provide a default reaction kinetic expression or allow entry of the expression
- allow some species to be set at fixed concentrations
- allow some species to be calculated using the steady-state assumption
- accept entry of the initial concentrations and reaction parameters
- formulate the set of differential equations for solving composition over time for either a CSTR or a plug flow reactor
- solve the differential equations symbolically if feasible
- numerically solve the differential equations over a specified time period
- plot the compositions over time
- solve the equations for the steady-state solution
- output the differential equation formulas as Fortran, C, Visual Basic or Matlab code

Maple's capabilities allowed me to write the application with minimal effort. The task would have been much too hard for me to do with other programming tools.

The application works well. I have applied it with numerous reaction steps and numerically stiff systems. It is so nice to have the error-free Fortran code and a trial solution from Maple when porting the differential equations to Fortran/Excel for fast

execution times. The calculations can be slow in Maple since it is an interpreted language. The speed improvement in going to Fortran is in the order of 1000 fold.

Conclusion

I have attempted to show you how the Maple software has impacted my capabilities to perform chemical engineering calculations. It has been beneficial to me on numerous occasions. It allowed me to perform math modeling tasks that I could not have tackled otherwise. It also enabled me to regain my usage of mathematics.

The price for a single commercial license is significant. I recommend that you consider a network license at your company. The cost is not much more and it lets many people have access to the software (one per license at a time, of course).

References

Friedler, F., K. Tarjan, Y. W. Huang and L T. Fan (1993), Graph-Theoretic Algorithm for Maximal Structure Generation. *Computers chem. Engng*, **17**, 9, 929-942.

Friedler, F., J. B. Varga and L. T. Fan (1995). Decision-Mapping: A Tool for Consistent and Complete Decisions in Process Synthesis. *Chemical Engineering Science*, **50**, 11, 1735-1768.

Partin, L. R., "Combinatorial Analysis Application for Flowsheet Synthesis of Chemical Plants," *MapleTech*, 5, 2/3 (1998), pp. 15-26.

Peterson, E. and L. R. Partin, "Temperature Sequences for Categorizing All Ternary Distillation Boundary Maps," *Ind. Eng. Chem. Res.*, 1997, 36, 1799-1811.

Szirtes, Thomas, "Applied Dimensional Analysis and Modeling," McGraw-Hill (1997) ISBN 0-07-062811-4